



Evolution of Cosmic Web Kinematics

-- from potential to vortical flow

Xin Wang (JHU)

Alex Szalay(JHU), Miguel A. Arogon-Calvo(JHU), Mark Neyrinck(JHU)

Large-scale Structure

- **Cosmic web structure**
 - Density
 - Halo, filament, wall
- **Coherent evolution of velocity and density**
 - Halo, filament, wall ...

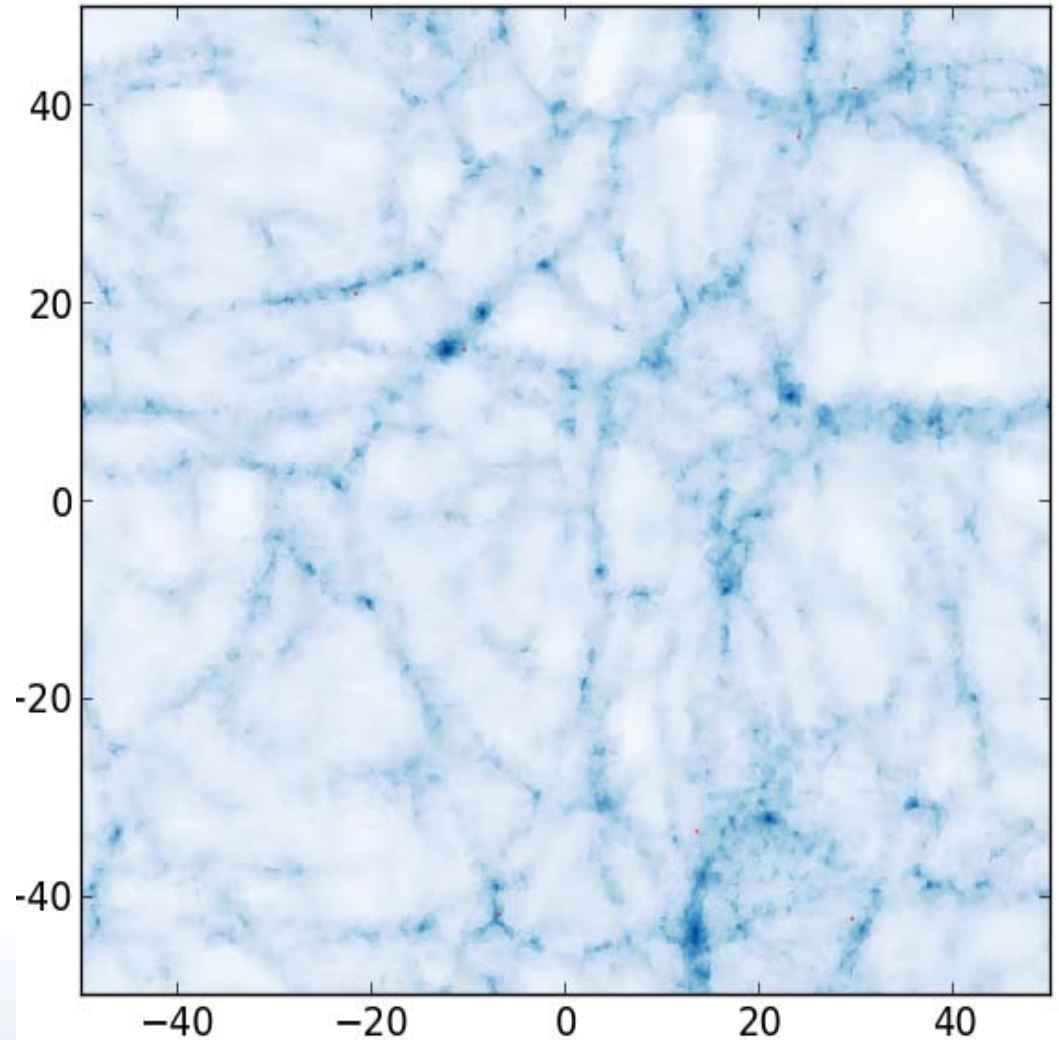

Large-scale Structure

- Coherent evolution of velocity and density

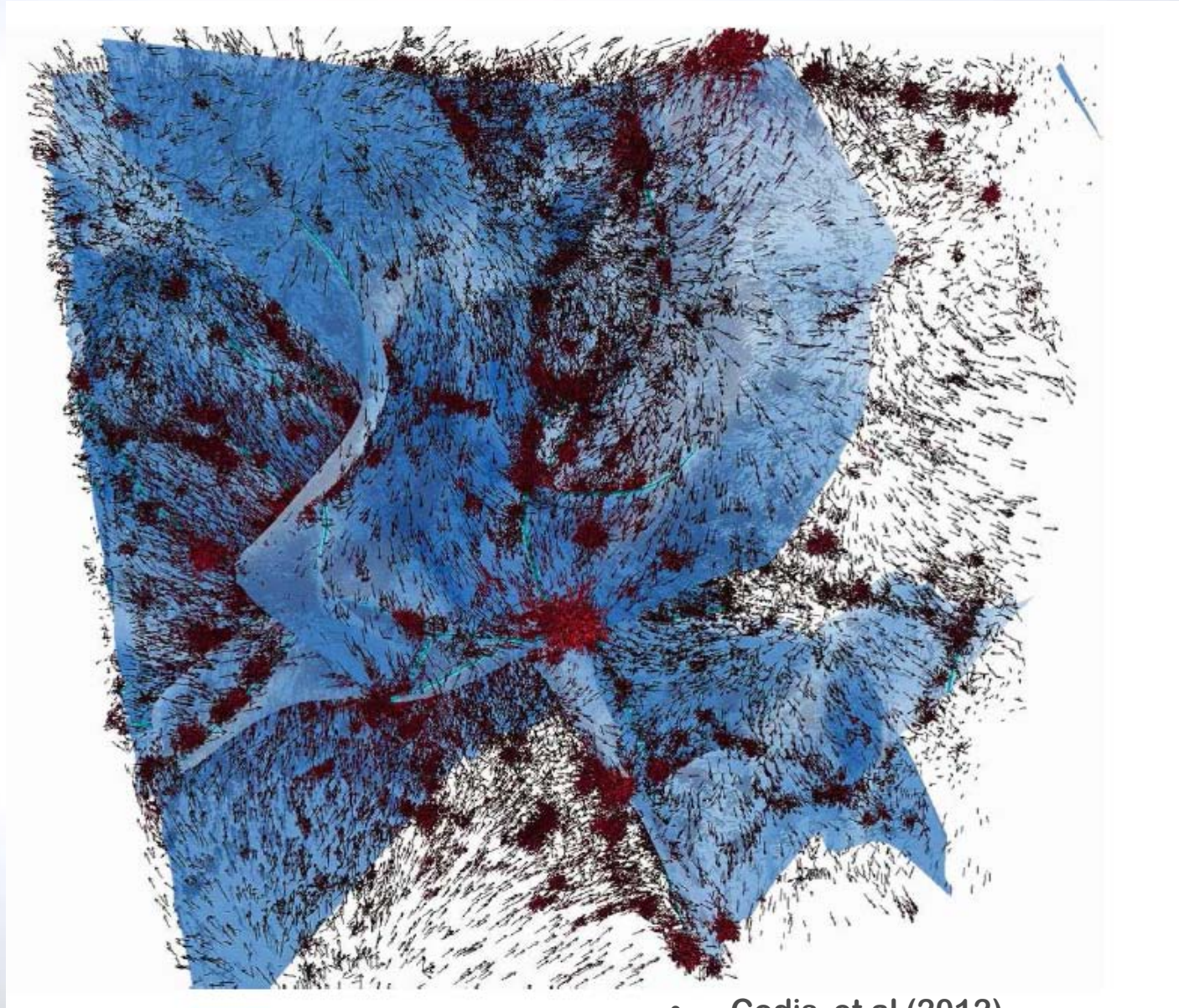

• Codis et al (2012)



Large-scale Structure

- Co
ev
vel
de

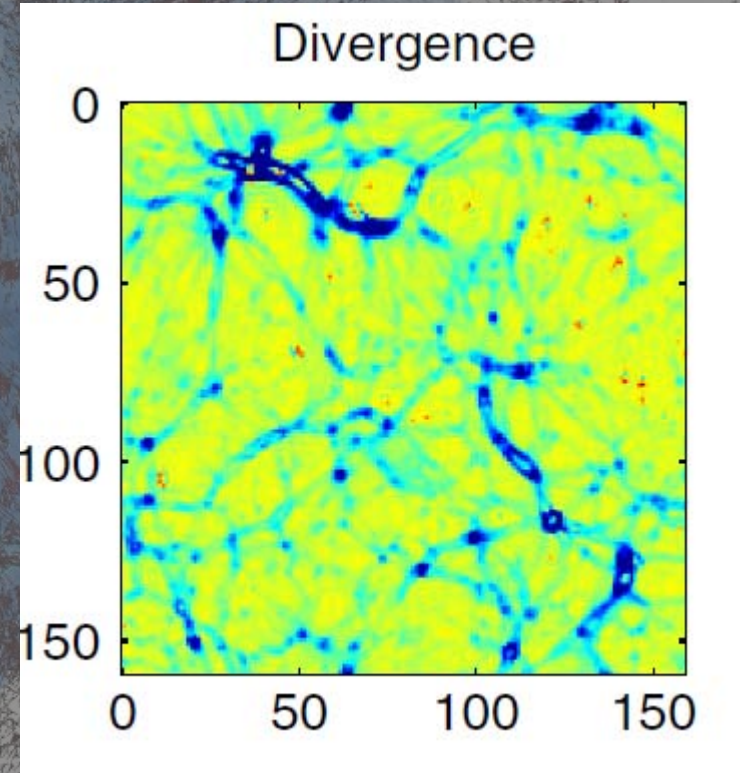
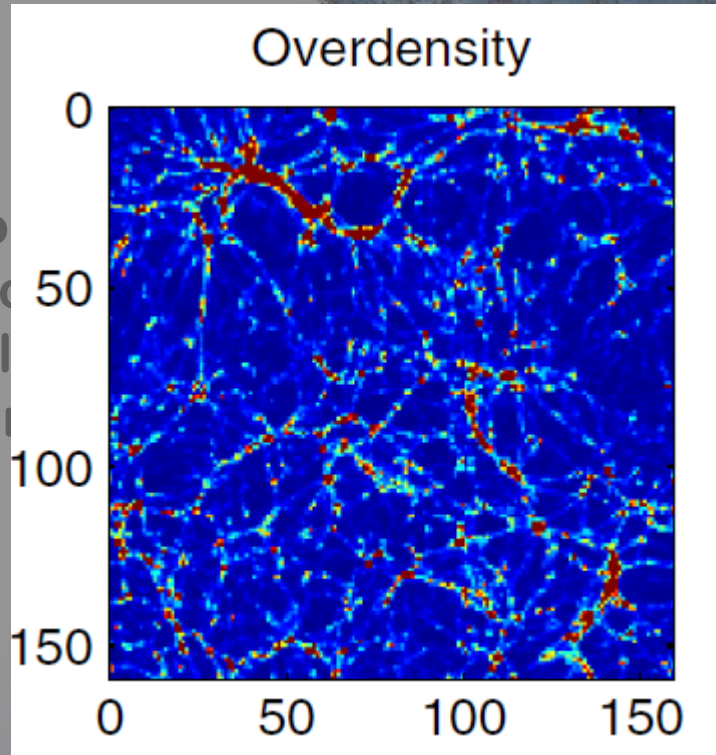

- Pueblas et al (2009)



Vortical flow

- **cosmic web & vorticity**
 - After Shell-crossing

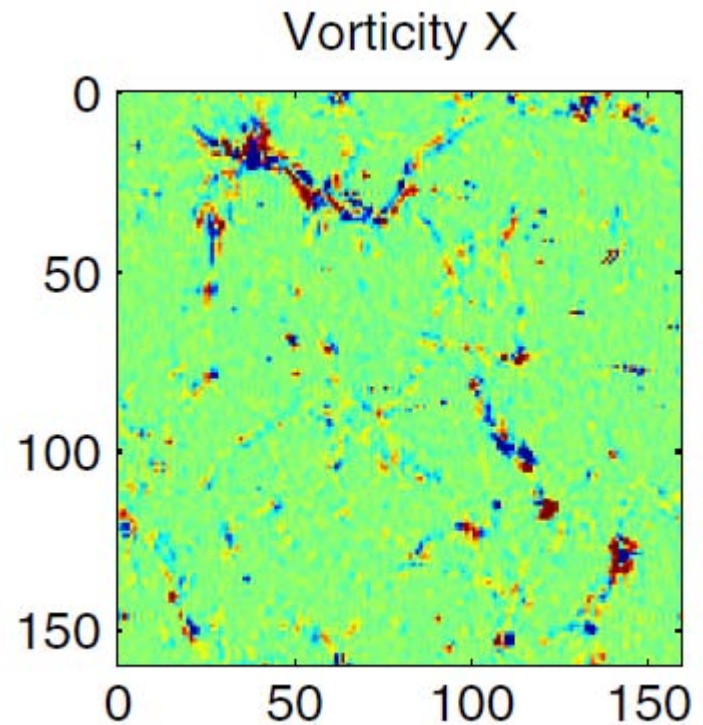
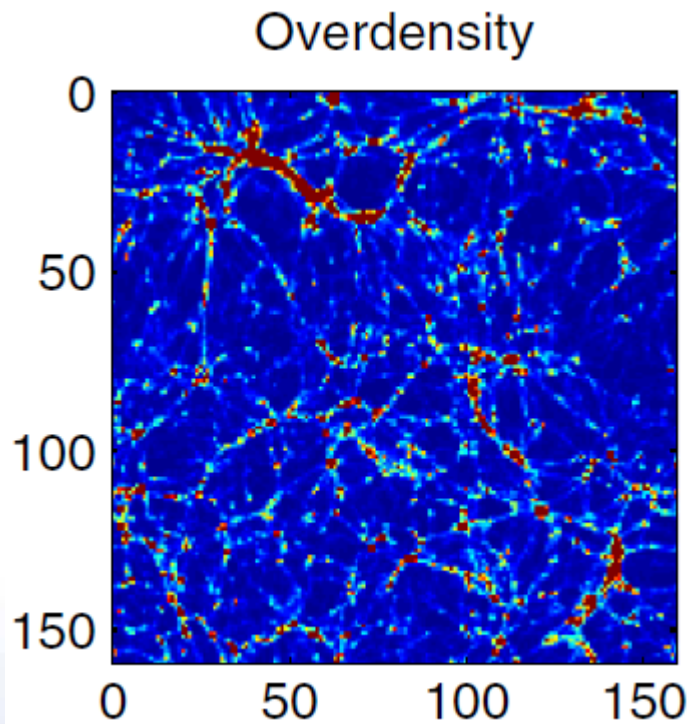

- Pueblas et al (2009)

Vortical flow – *vorticity orientation*

- cosmic web \rightarrow vorticity \rightarrow halo spin

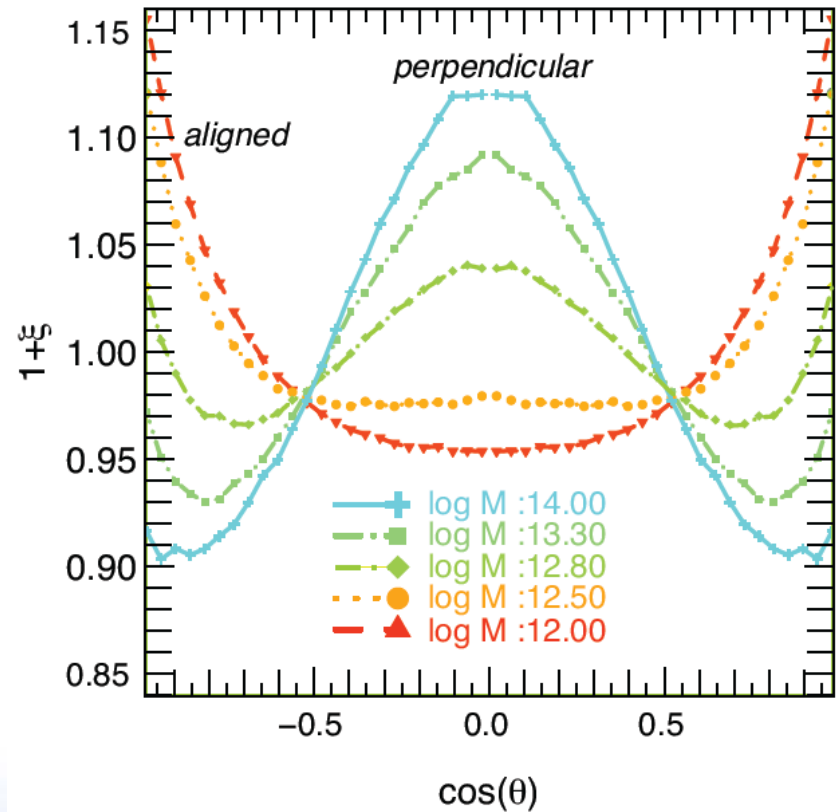
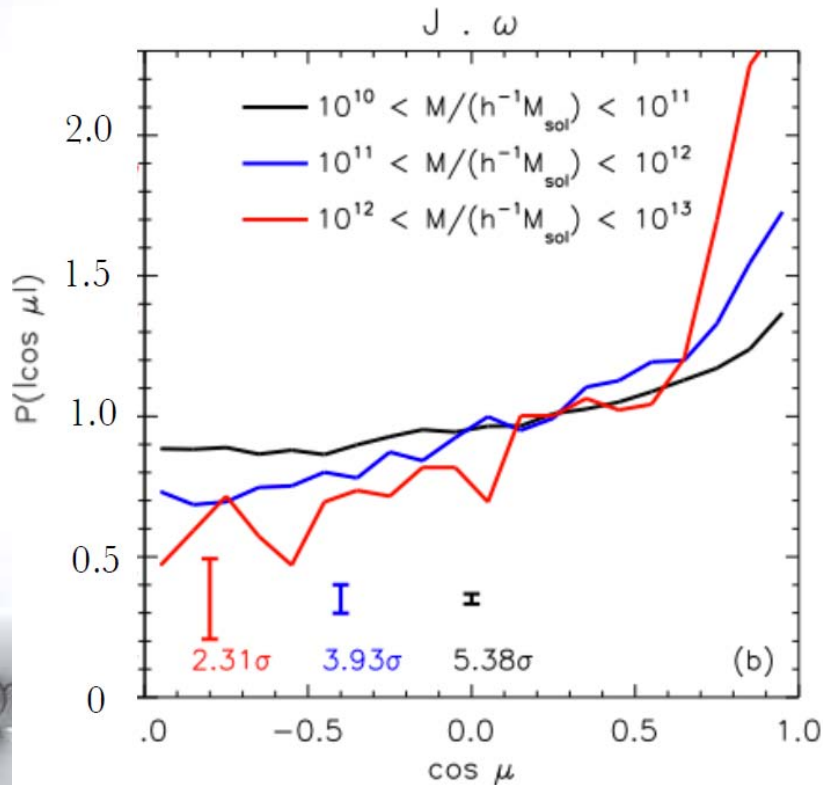

- Libeskind et al. (2013)

- Codis et al (2012)

Invariants of velocity gradient

- *How to study?*
 - *Evolution of peculiar velocity?*
- **Decomposition:**
 - divergence, vorticity:

$$\dot{\theta} = \nabla \cdot \mathbf{u} \quad \mathbf{w} = \nabla \times \mathbf{u}$$

- **Evolution equation**

$$\frac{\partial \mathbf{u}(\mathbf{x}, \tau)}{\partial \tau} + \mathcal{H}(\tau) \mathbf{u}(\mathbf{x}, \tau) + \mathbf{u}(\mathbf{x}, \tau) \cdot \nabla \mathbf{u}(\mathbf{x}, \tau) = -\nabla \Phi(\mathbf{x}, \tau) - \frac{1}{\rho} \nabla_j (\rho \sigma_{ij}) ,$$

- **Linear regime**

$$\frac{\partial \theta(\mathbf{x}, \tau)}{\partial \tau} + \mathcal{H}(\tau) \theta(\mathbf{x}, \tau) + \frac{3}{2} \Omega_m(\tau) \mathcal{H}^2(\tau) \delta(\mathbf{x}, \tau) = 0 ,$$

$$\frac{\partial \mathbf{w}(\mathbf{x}, \tau)}{\partial \tau} + \mathcal{H}(\tau) \mathbf{w}(\mathbf{x}, \tau) = 0 .$$



Cosmic flow

- In general:

$$A_{ij}(\mathbf{x}, \tau) = \frac{\partial u_i}{\partial x_j}(\mathbf{x}, \tau).$$

- Kinematical classification

$$\frac{dx_i}{d\tau}(\mathbf{x}) = u_i(\mathbf{x}) = u_i(\mathbf{x}_0) + A_{ij}(\mathbf{x}_0)x_j + \dots$$

- where $\mathbf{A} = \mathbf{R}^{-1} \begin{pmatrix} \lambda_1 & & \\ & \lambda_2 & \\ & & \lambda_3 \end{pmatrix} \mathbf{R},$

- halo: $\lambda_i < 0,$
- void: $\lambda_i > 0$
- filament / wall: indefinite

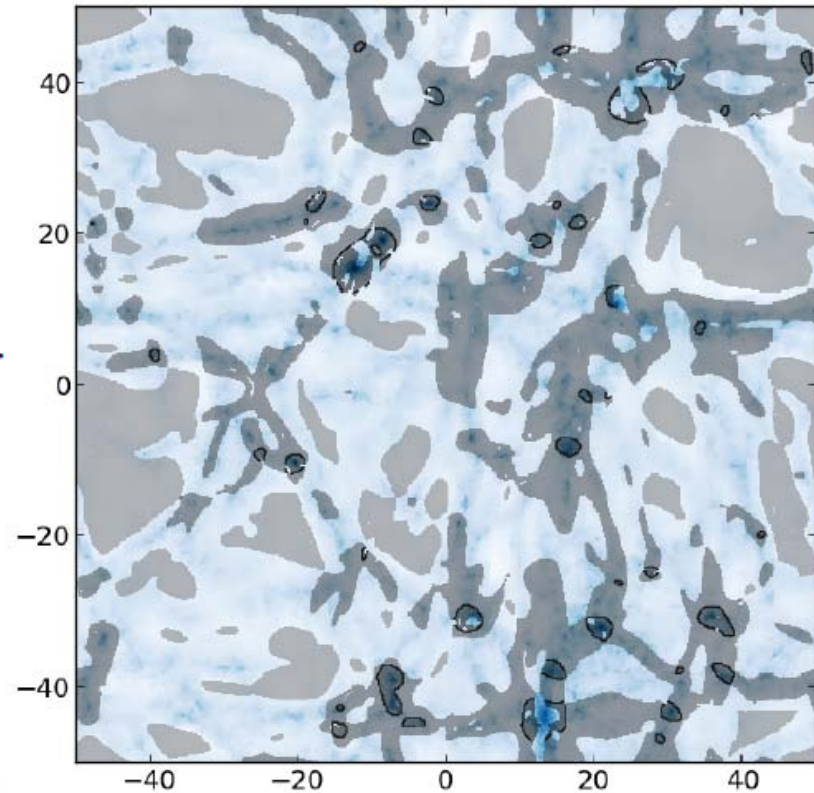

Cosmic flow

- Velocity decomposition

• in g

• Kin \mathcal{P}

• whe

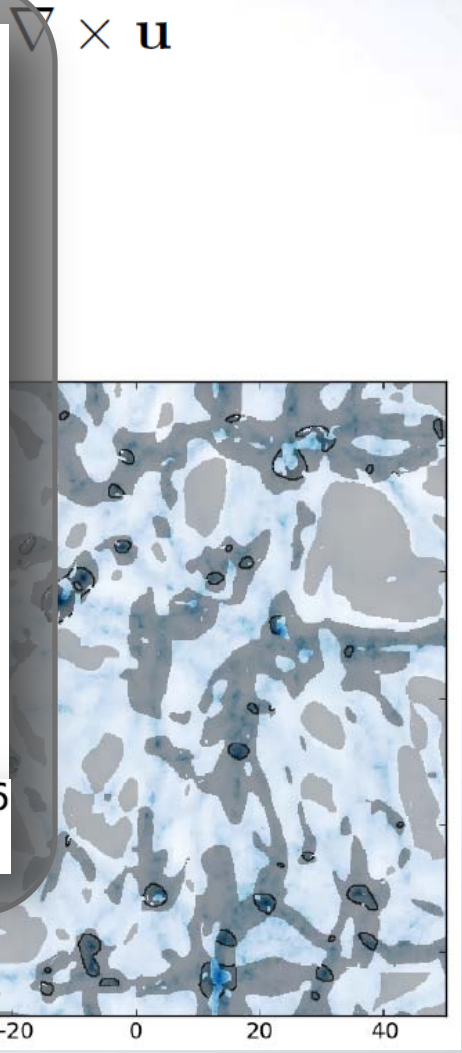
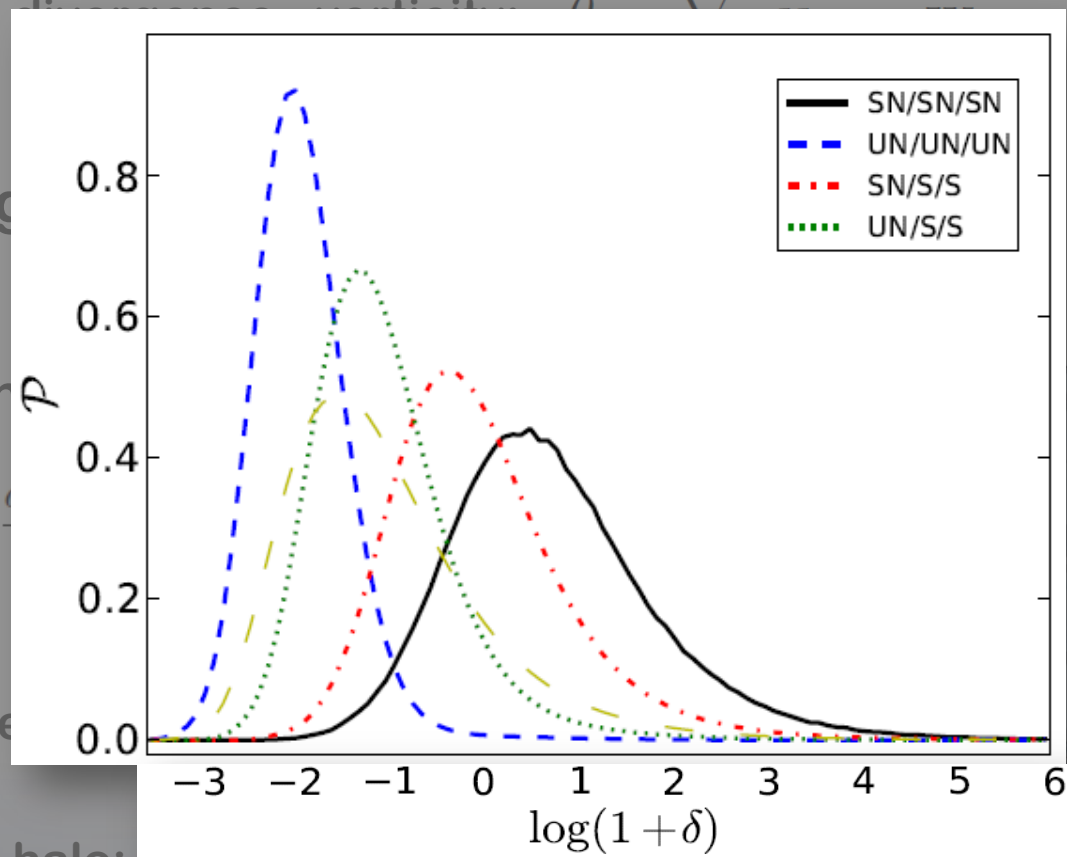

- halo: $\lambda_i < 0$,
- void: $\lambda_i > 0$
- filament / wall: indefinite



Invariants of velocity gradient

- Vortical flow?
 - Complex eigenvalues

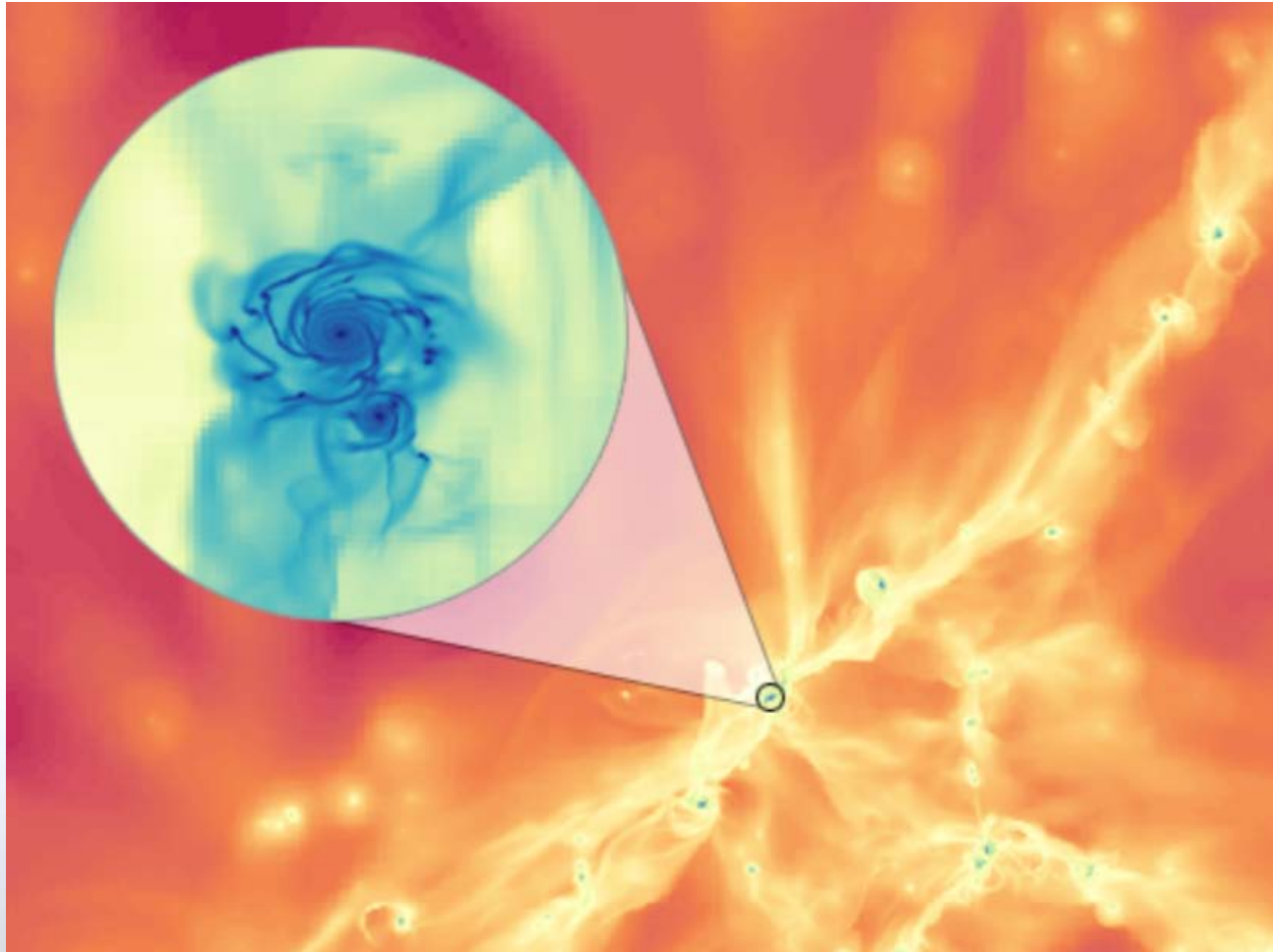

Invariants of velocity gradient

- Vortical flow?
 - Complex eigenvalues
- Alternatively, more general

$$\det[\mathbf{A} - \lambda\mathbf{I}] = \lambda^3 + s_1\lambda^2 + s_2\lambda + s_3 = 0,$$

- Define **invariants of velocity gradient**
 - (Turbulence 20+ years)

$$s_1 = -\text{tr}[\mathbf{A}] = -\theta_{ii},$$

$$s_2 = \frac{1}{2} (s_1^2 - \text{tr}[\mathbf{A}^2]) = \frac{1}{2} (s_1^2 - \theta_{ij}\theta_{ji} - \omega_{ij}\omega_{ji})$$

$$\begin{aligned} s_3 &= -\det[\mathbf{A}] = \frac{1}{3} (-s_1^3 + 3s_1s_2 - \text{tr}[\mathbf{A}^3]) \\ &= \frac{1}{3} (-s_1^3 + 3s_1s_2 - \theta_{ij}\theta_{jk}\theta_{ki} - 3\omega_{ij}\omega_{jk}\theta_{kl}), \end{aligned}$$



Invariants of velocity gradient

- Invariants-space

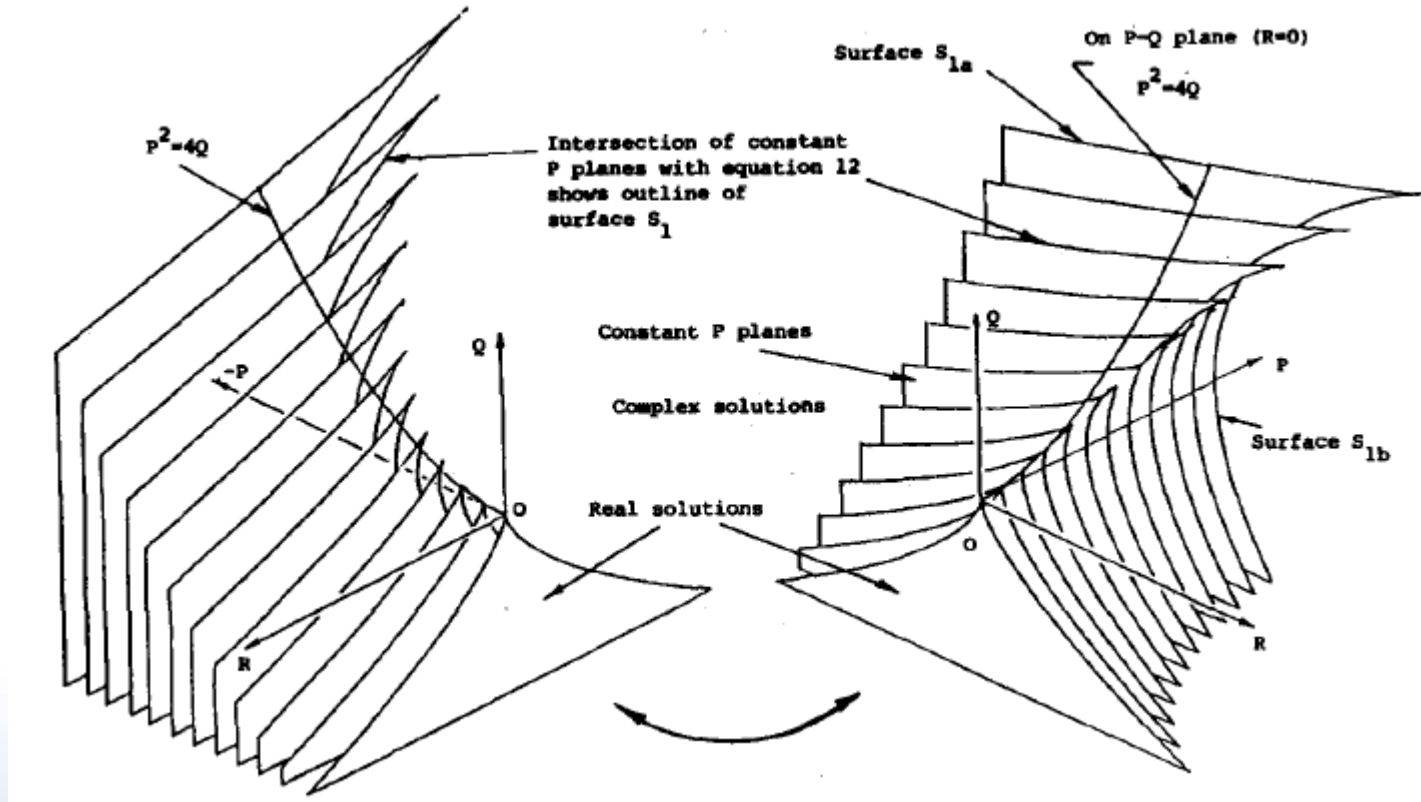

- Turbulence, Chong et. al, 1990

Kinematics of Cosmic Web

- **Mapping:** eigenvalue space \rightarrow Invariant space

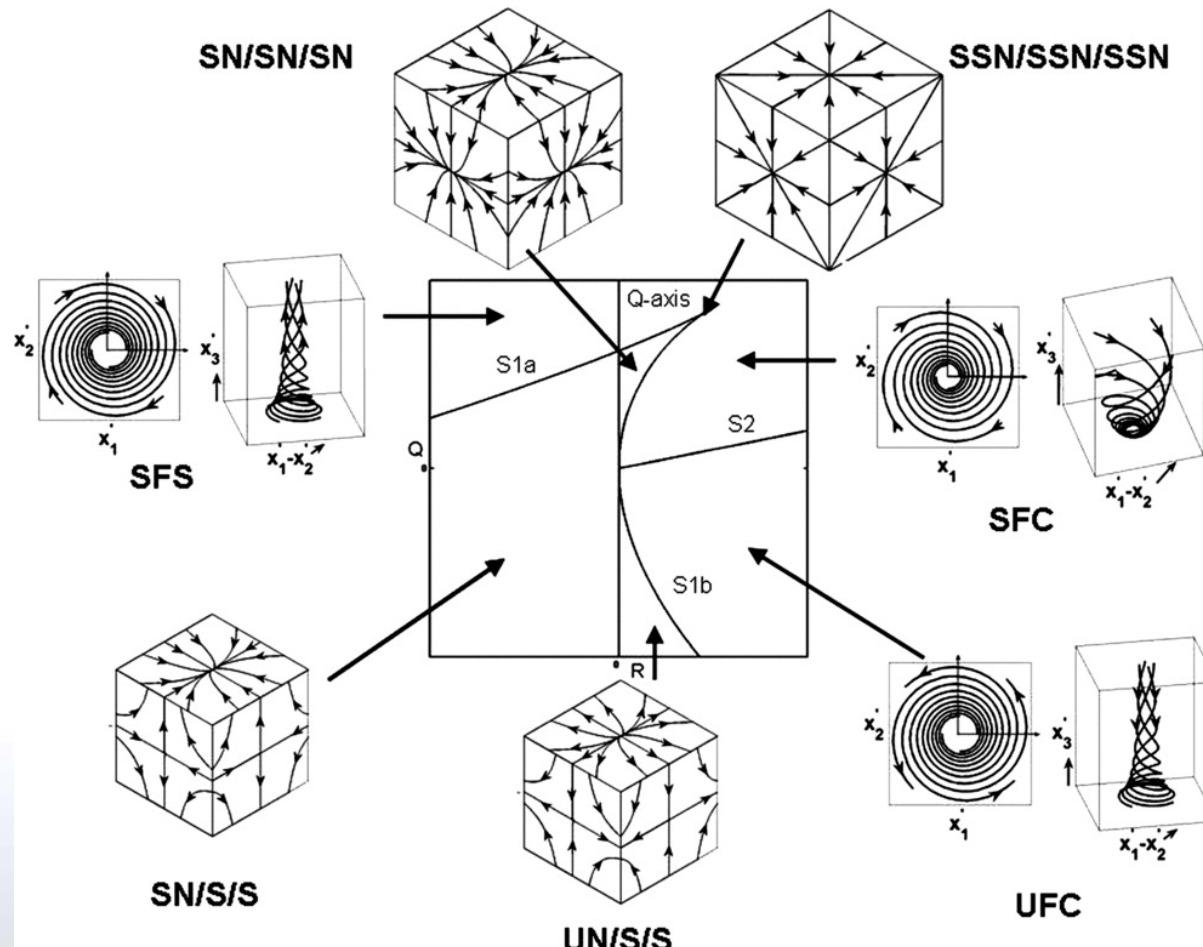

Kinematics of Cosmic Web

- **Mapping:** eigenvalue space \rightarrow Invariant space

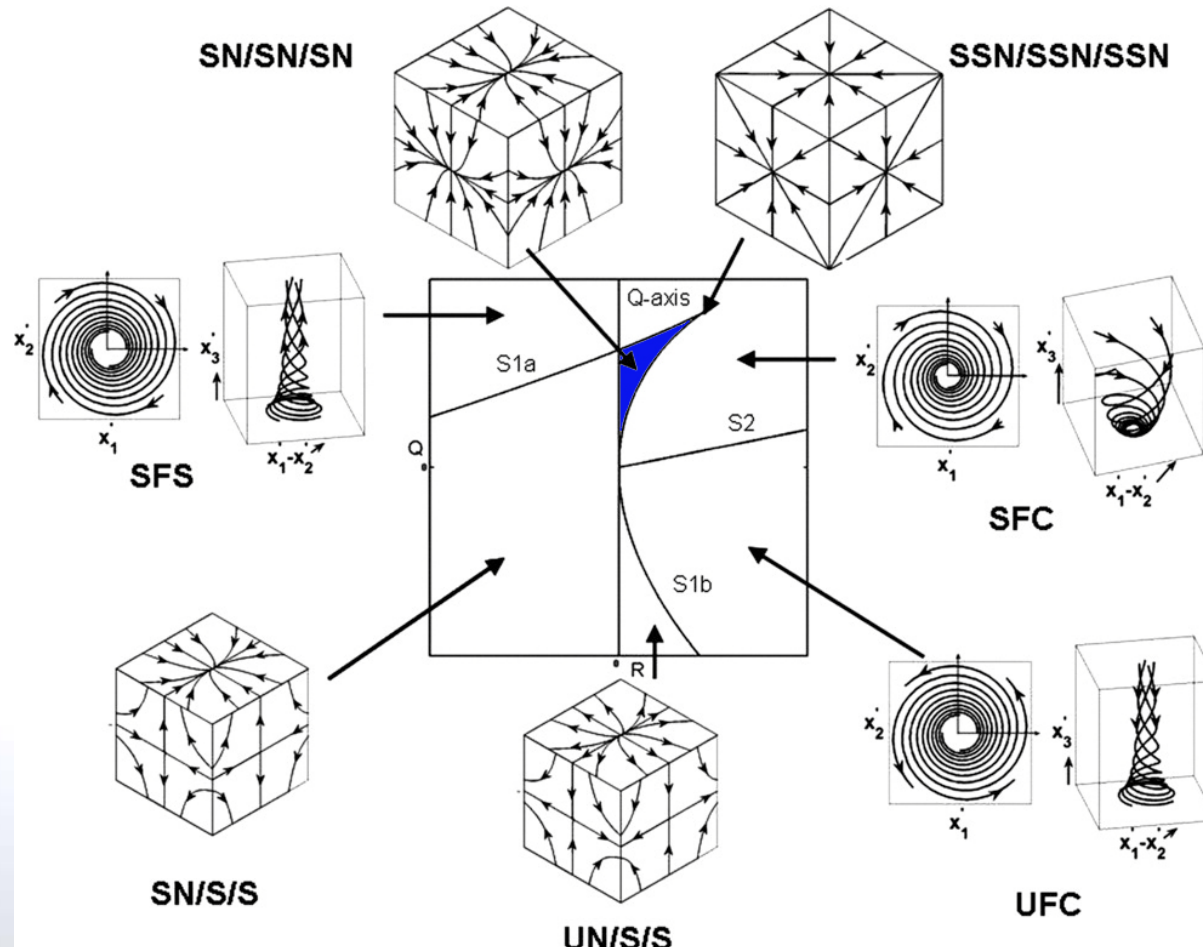

Kinematics of Cosmic Web

- **Mapping:** eigenvalue space \rightarrow Invariant space

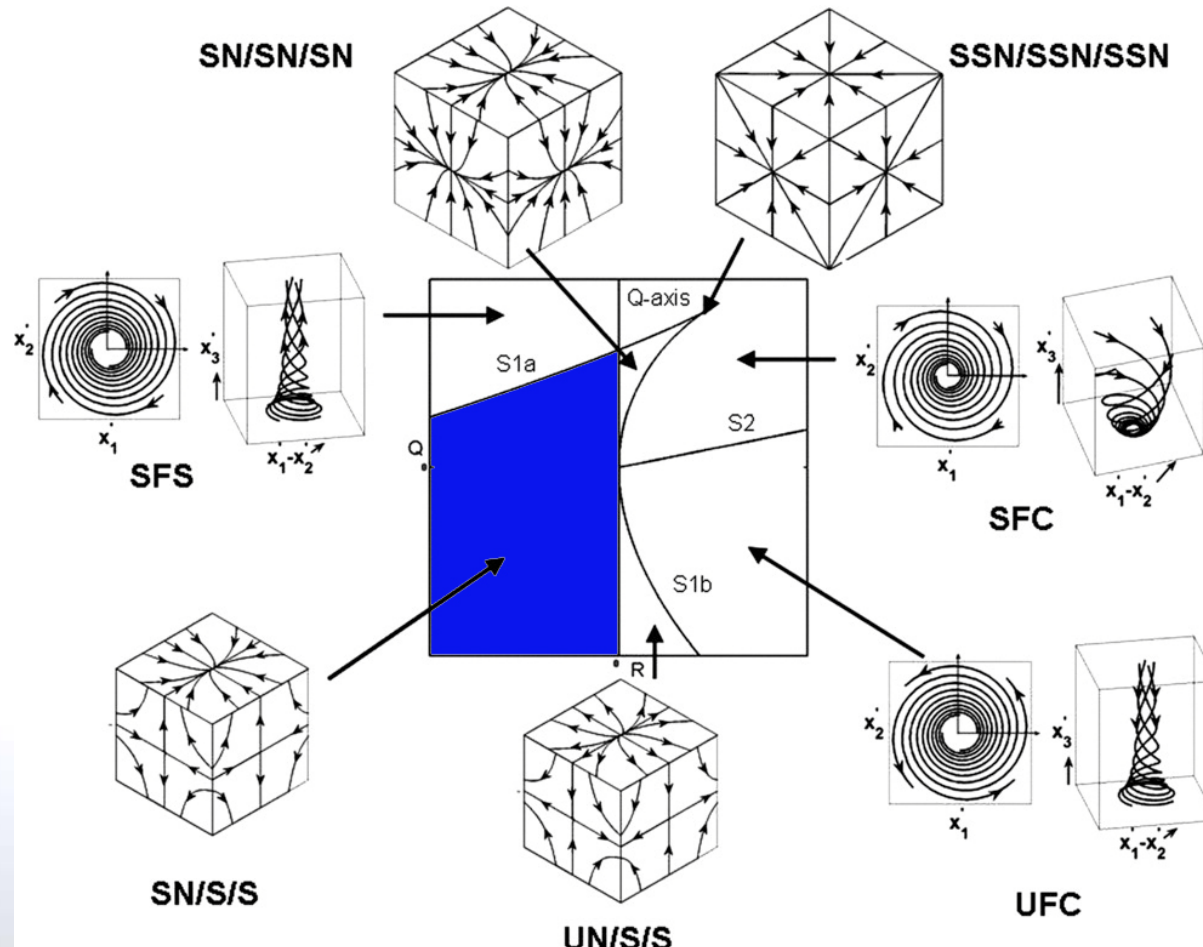

Kinematics of Cosmic Web

- **Mapping:** eigenvalue space \rightarrow Invariant space

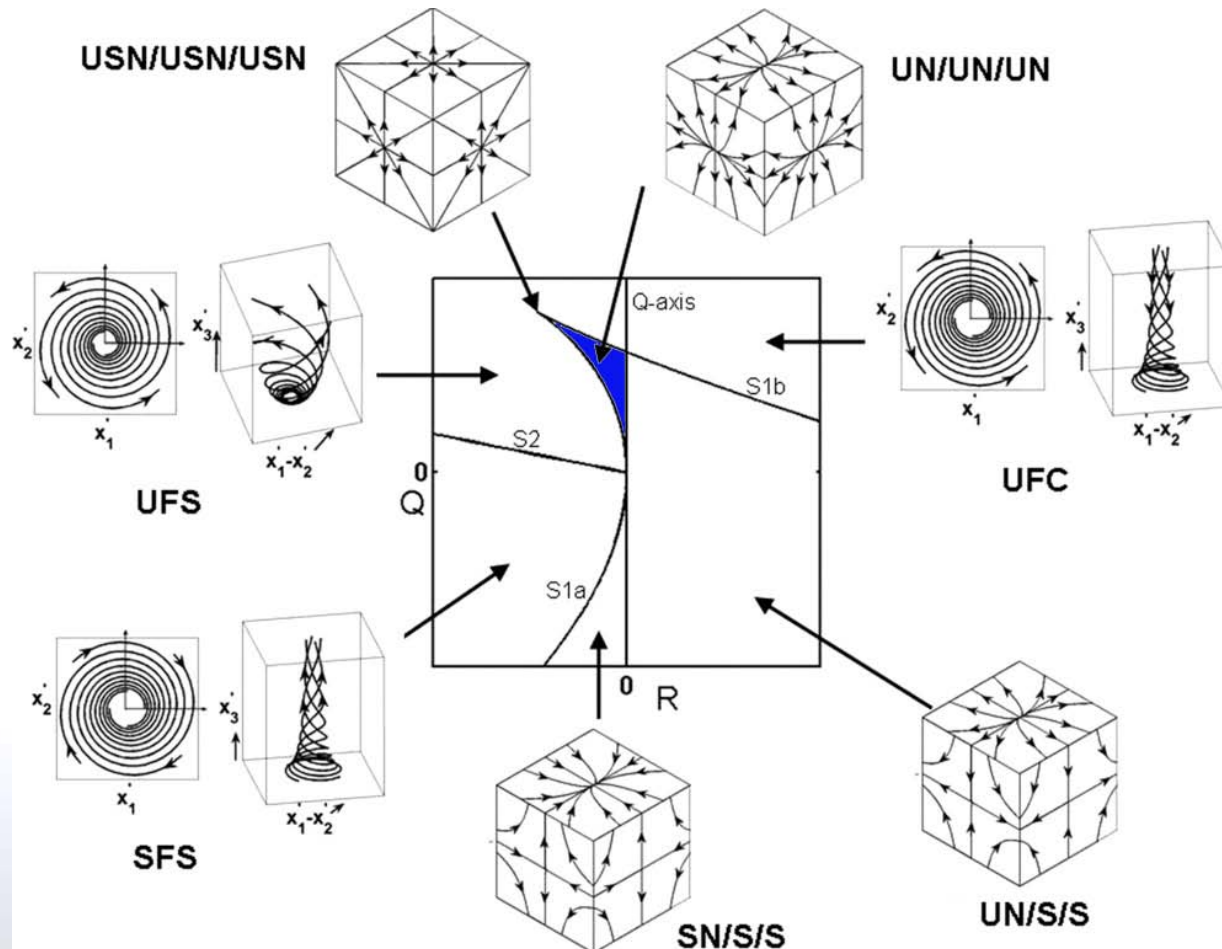



Evolution of Cosmic Web Dynamics

--- potential flow

Xin Wang (JHU)

Alex Szalay(JHU), Miguel A. Arogon-Calvo(JHU), Mark Neyrinck(JHU)

Dynamics of Cosmic-Web

- Dynamical evolution:
 - Euler-Poisson system

$$\frac{\partial \mathbf{u}}{\partial \tau} + \mathcal{H}(\tau)\mathbf{u}(\mathbf{x}, \tau) + \mathbf{u}(\mathbf{x}, \tau) \cdot \nabla \mathbf{u}(\mathbf{x}, \tau) = -\nabla \Phi(\mathbf{x}, \tau)$$

$$\frac{dA_{ij}}{d\tau} + \mathcal{H}(\tau)A_{ij} + A_{ik}A_{kj} = \varpi_{ij} \quad , \text{ where } \varpi_{ij}(\mathbf{x}, \tau) = -\nabla_i \nabla_j \Phi(\mathbf{x}, \tau)$$

- Invariants evolution

$$\frac{d}{d\tau}s_1 + \mathcal{H}(\tau)s_1 - s_1^2 + 2s_2 = -\varpi$$

$$\frac{d}{d\tau}s_2 + 2\mathcal{H}(\tau)s_2 - s_1s_2 + 3s_3 = -s_1\varpi - \varpi_A$$

$$\frac{d}{d\tau}s_3 + 3\mathcal{H}(\tau)s_3 - s_1s_3 = -s_2\varpi - s_1\varpi_A - \varpi_{A^2}$$

- where

$$\varpi = \varpi_{ii} = -\nabla^2 \Phi$$

$$\varpi_{A^2} = \varpi_{ik}A_{kj}A_{ji}$$



Dynamics of Cosmic-Web

- Coupled equations
 - Newton potential

$$\varpi = \varpi_{ii} = -\nabla^2\Phi$$

$$\frac{d}{d\tau}\varpi + \left[\frac{d}{d\tau} \ln \mathcal{N}(\tau) - s_1 \right] \varpi - \frac{1}{\mathcal{N}}(\tau) s_1 = 0,$$

- Tidal field

$$\begin{aligned} \frac{d}{d\tau}\varepsilon_{ij} + \mathcal{H}(\tau)\varepsilon_{ij} + \nabla_k \epsilon^{kl} ({}_i H_{j)l} + \theta\varepsilon_{ij} + \delta_{ij}\sigma^{kl}\varepsilon_{kl} \\ - 3\sigma^k ({}_i \varepsilon_{j)k} - \omega^k ({}_i \varepsilon_{j)k} = -\varpi\sigma_{ij}. \end{aligned}$$

where H_{ij} is Newtonian limit of magnetic part of Weyl tensor



Dynamics of Cosmic-Web

- Zel'dovich approximation

$$\mathbf{x}(\tau) = \mathbf{q} + \Psi(\mathbf{q}, \tau) \approx \mathbf{q} + D(\tau)\Psi_1(\mathbf{q}),$$

- Velocity evolution

$$\tilde{\mathbf{u}}' = \frac{d\tilde{\mathbf{u}}}{dD} = \left(\frac{\partial}{\partial D} + \tilde{\mathbf{u}} \cdot \nabla \right) \tilde{\mathbf{u}} = 0,$$

- Velocity gradient evolution

$$\frac{d\tilde{A}_{ij}}{dD} + \tilde{A}_{ik}\tilde{A}_{kj} = 0$$

- Evolution of invariants

$$\begin{aligned} \tilde{s}'_1 - \tilde{s}_1^2 + 2\tilde{s}_2 &= 0, \\ \tilde{s}'_2 - \tilde{s}_1\tilde{s}_2 + 3\tilde{s}_3 &= 0, \\ \tilde{s}'_3 - \tilde{s}_1\tilde{s}_3 &= 0. \end{aligned}$$

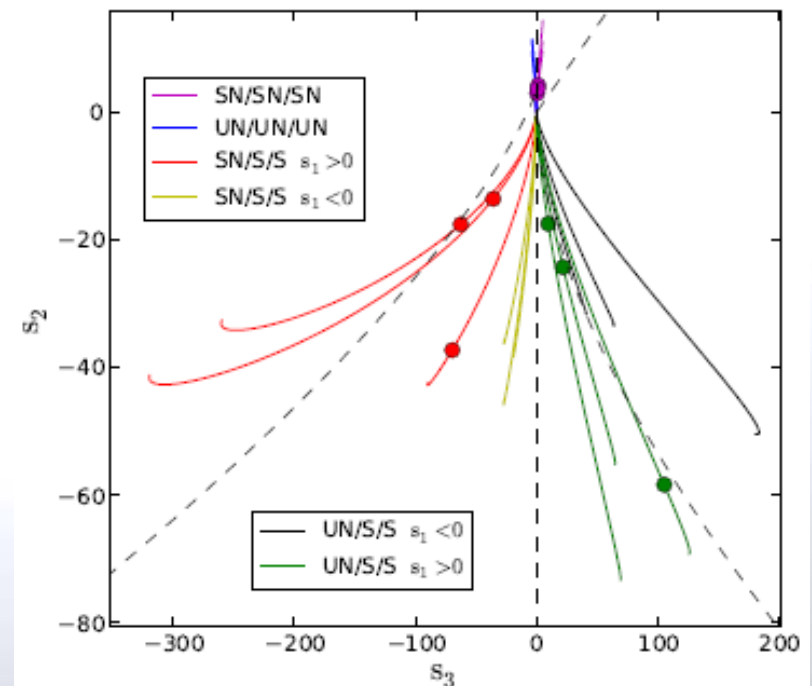

Dynamics of Cosmic-Web

- Zel'dovich approximation

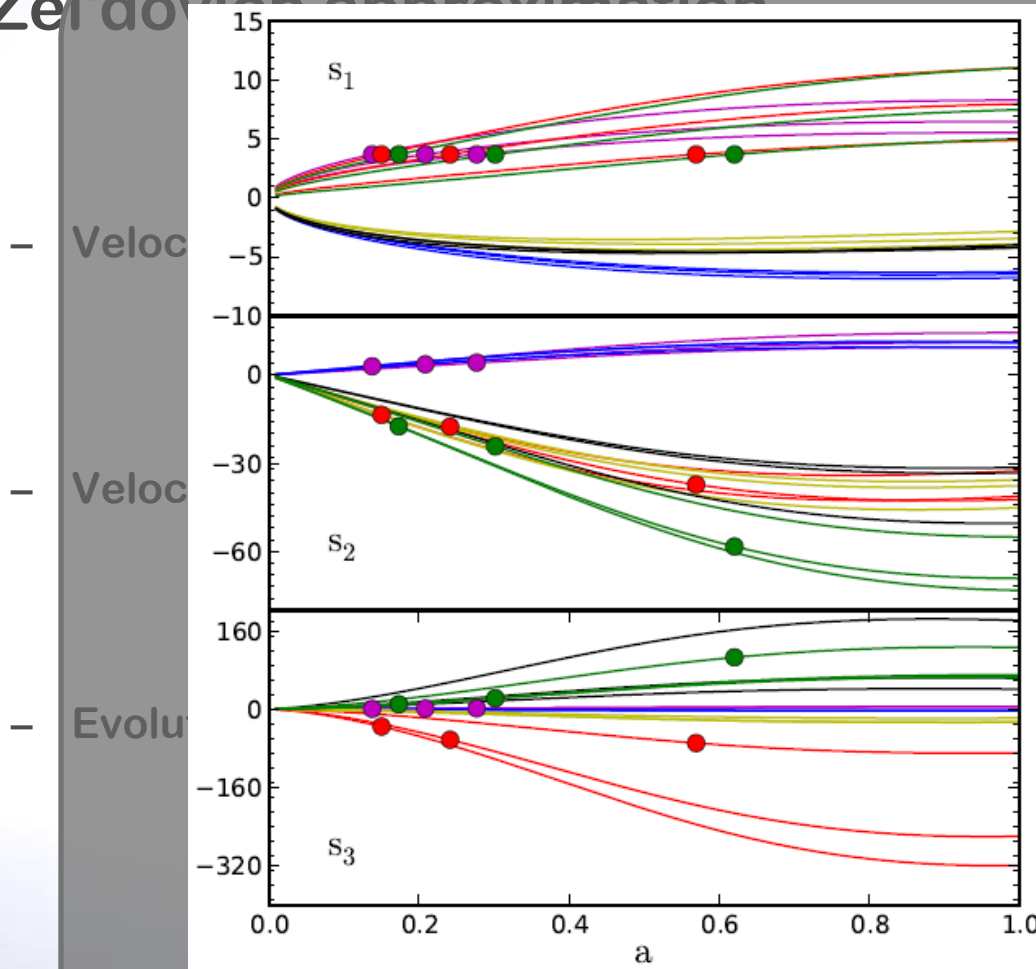

$$s'_3 - s_1 s_3 = 0.$$

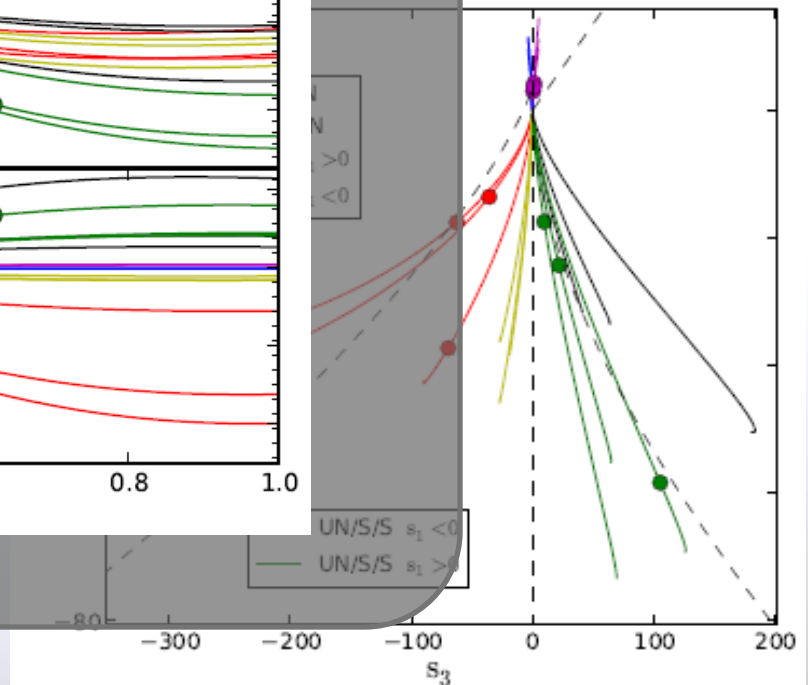

Probability Distribution

- Initial condition
 - Gaussian distribution

$$\mathcal{P} \left(\tilde{A}_{ij}^{(\xi)} \right) = \frac{1}{(2\pi)^3 \sqrt{|\mathbf{C}|}} e^{-(\mathbf{x}^T \cdot \mathbf{C}^{-1} \cdot \mathbf{x})/2},$$

$$\mathcal{P} \left(\tilde{s}_i^{(\xi)} \right) \prod_i d\tilde{s}_i^{(\xi)} d\Omega_{S_3} = \mathcal{P} \left(\tilde{A}_{ij}^{(\xi)} \right) \prod_{i \leq j} d\tilde{A}_{ij}^{(\xi)},$$

$$\mathcal{P} \left(\tilde{s}_i^{(\xi)} \right) = \frac{15^3}{8\pi\sqrt{5} \sigma^6} e^{-\frac{3}{2\sigma^2} \left[2\left(\tilde{s}_1^{(\xi)}\right)^2 - 5\tilde{s}_2^{(\xi)} \right]} \text{Real} \left(\tilde{s}_i^{(\xi)} \right)$$

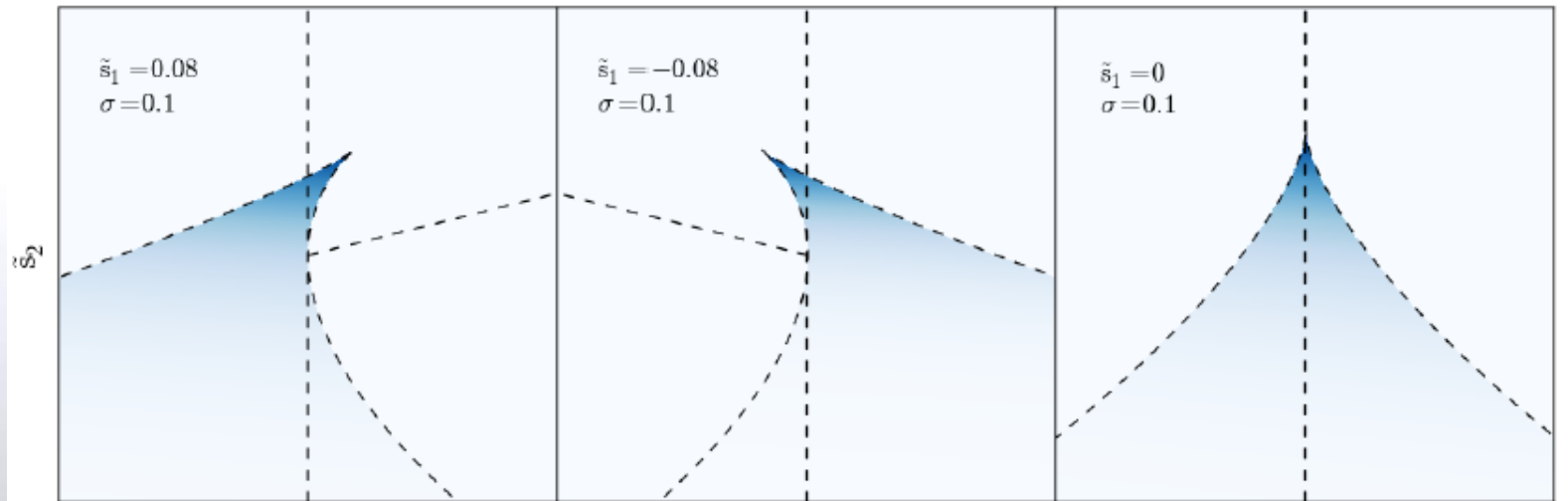

Probability Distribution

- Zel'dovich approximation

$$\tilde{A}_{ij} = \frac{A_{ij}(\tau)}{D^{(v)}(\tau)} = \frac{\partial \Psi_i}{\partial x_j} = \frac{\partial \Psi_i}{\partial q_k} (J^{-1})_{kj},$$

$$\mathcal{P}(\tilde{s}_i) = \mathcal{P}(\lambda_i) \left| \frac{\partial \lambda_i}{\partial \tilde{\eta}_k} \frac{\partial \tilde{\eta}_k}{\partial s_j} \right| = \frac{15^3}{8\pi\sqrt{5} \sigma^6 T^4} \text{Real}(\tilde{s}_i) \\ \times \exp \left[\frac{-3(\tilde{s}_1 + 2\tilde{s}_2 + 3\tilde{s}_3)^2}{\sigma^2 T^2} + \frac{15(3\tilde{s}_3 + \tilde{s}_2)}{2\sigma^2 T} \right],$$

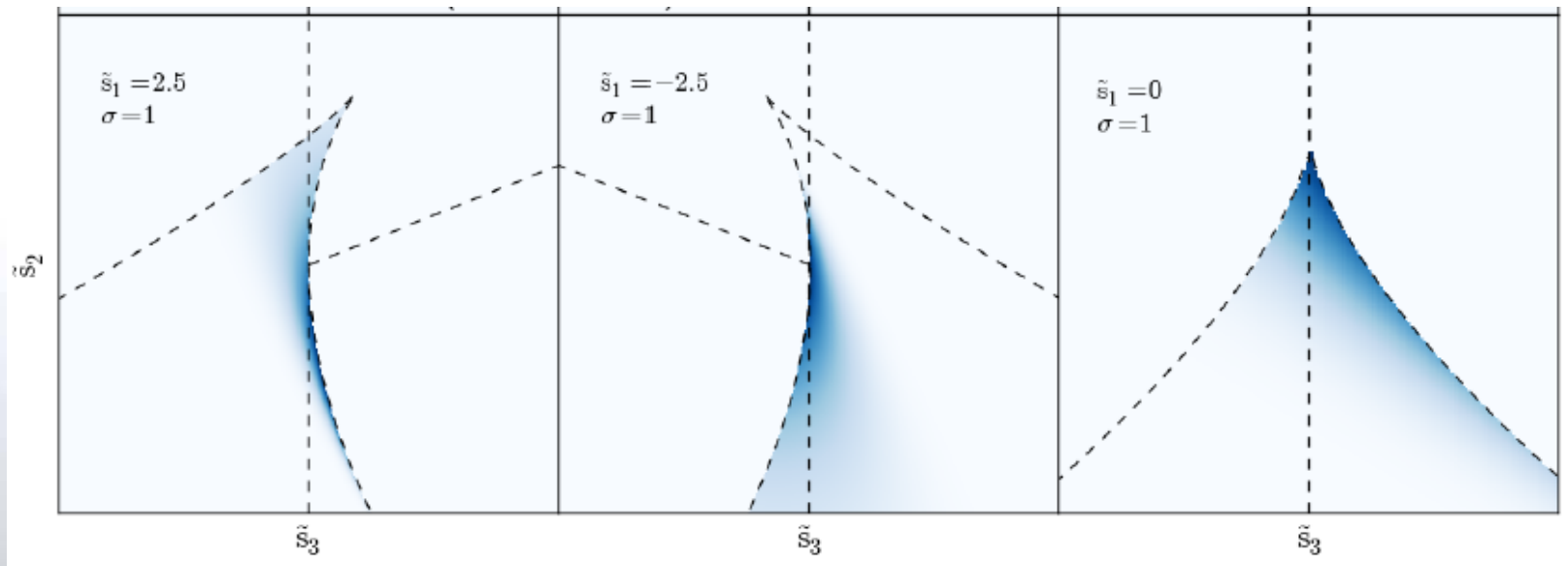

Beyond Zel'dovich Approximation

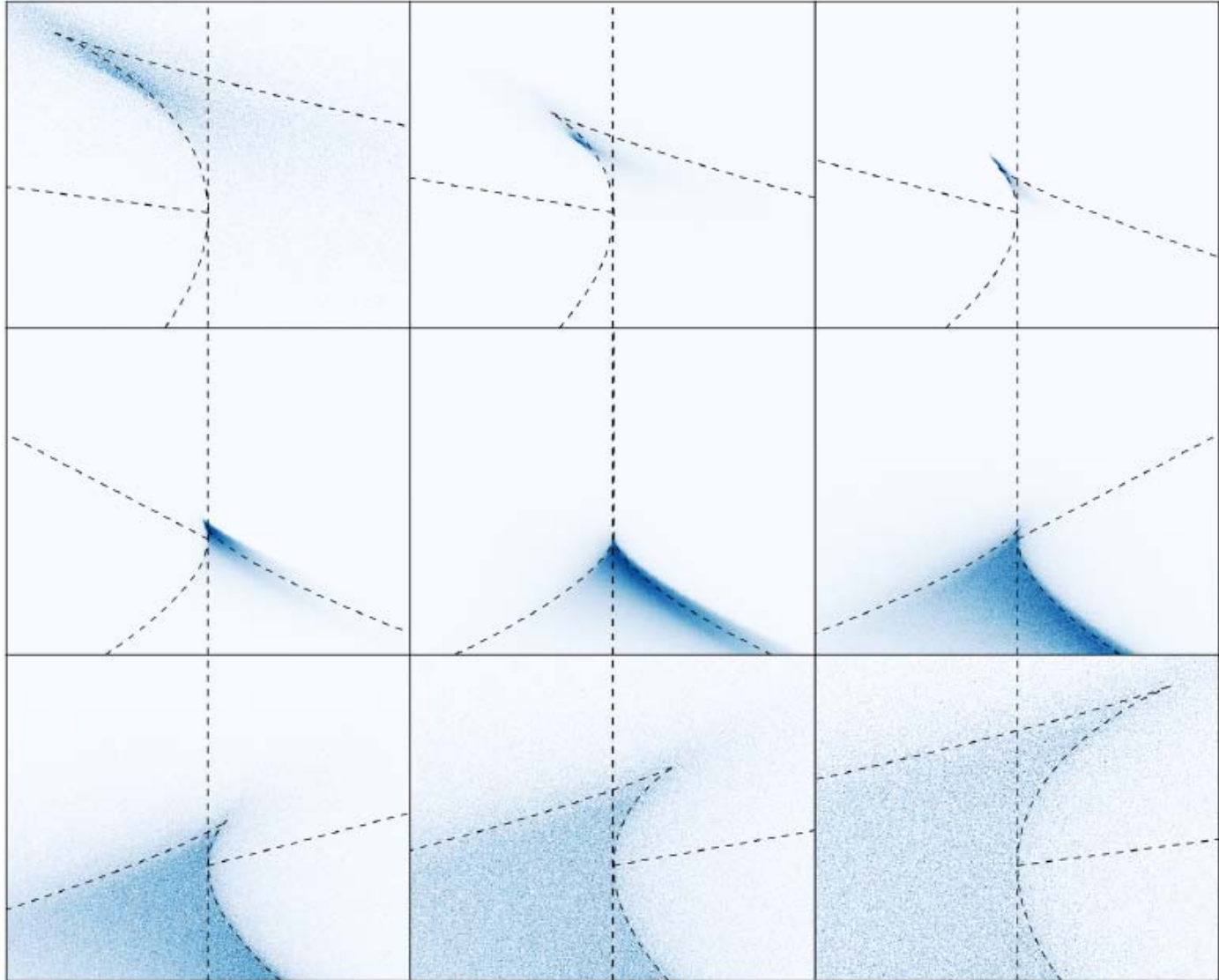



Evolution of Cosmic Web Dynamics

--- vortical flow

Xin Wang (JHU)

Alex Szalay(JHU), Miguel A. Arogon-Calvo(JHU), Mark Neyrinck(JHU)

Vortical flow – *spatial distribution*

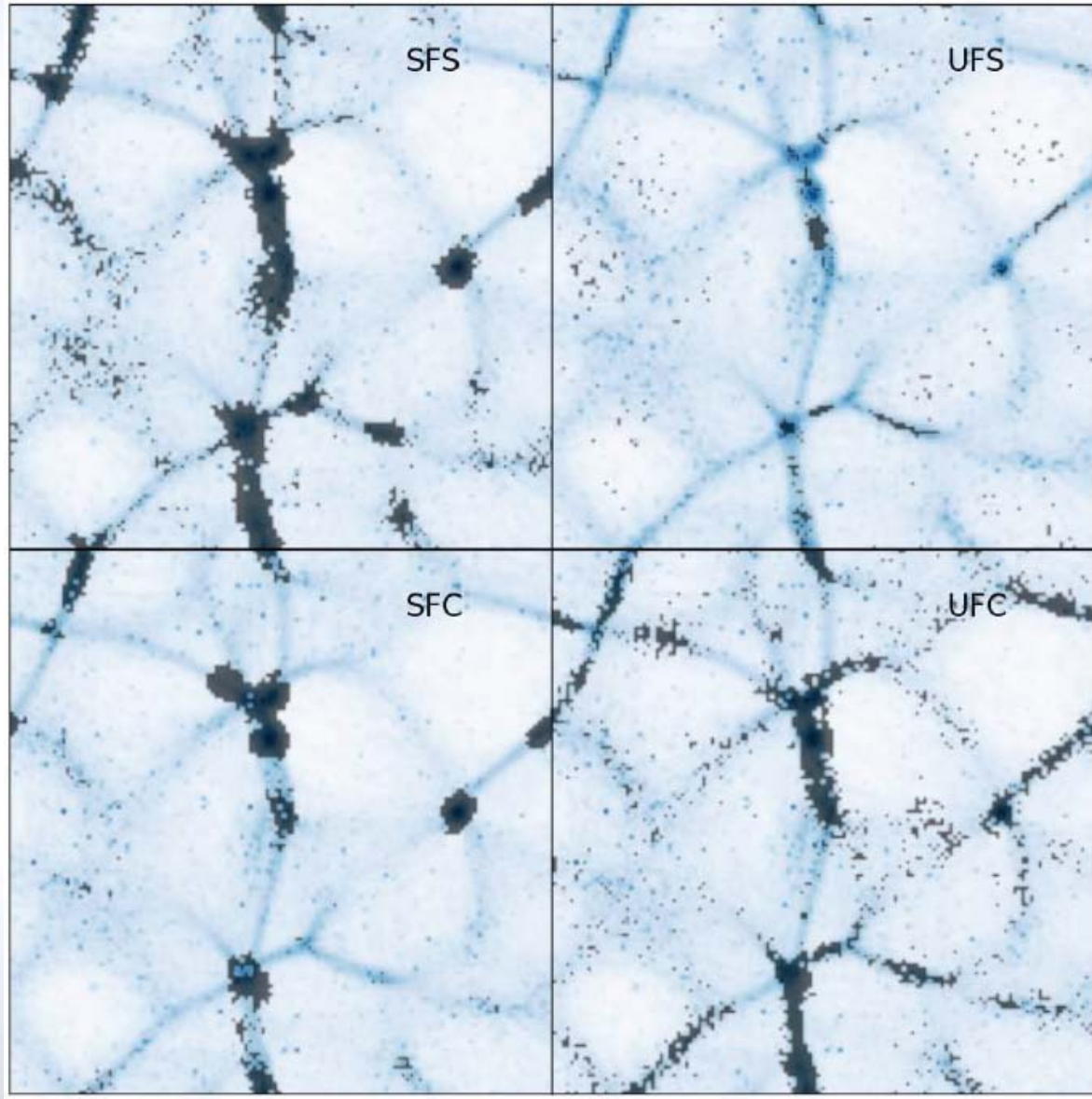

Vortical flow – *vorticity orientation*

- Flow-type dependence
 - angle between vorticity and velocity

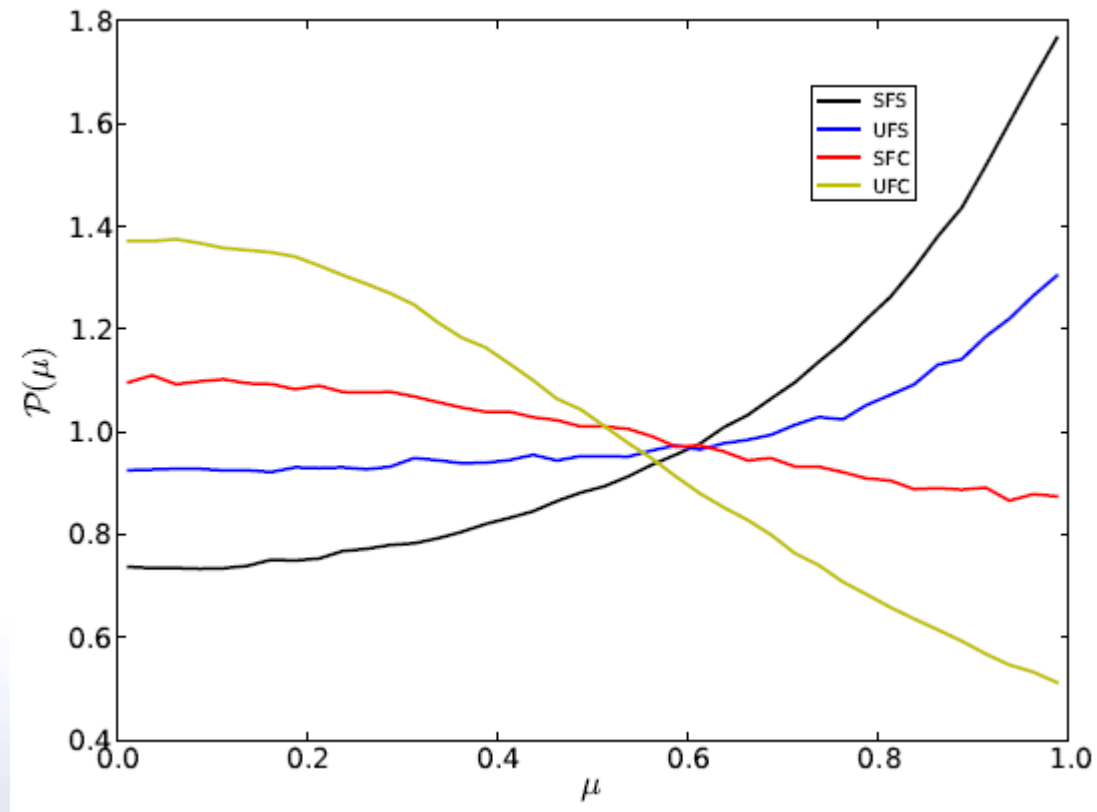

Vortical flow – *vorticity orientation*

- Flow-type dependence
 - angle between vorticity and structure direction

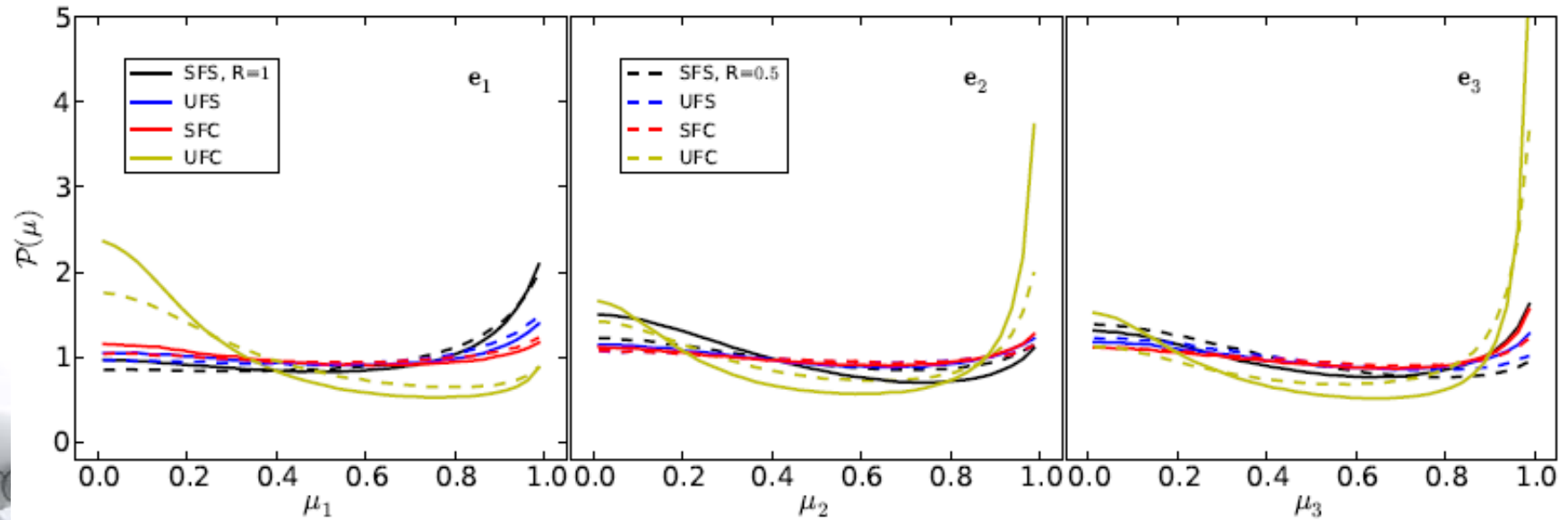

Vortical flow – vorticity orientation

- Vorticity & halo spin

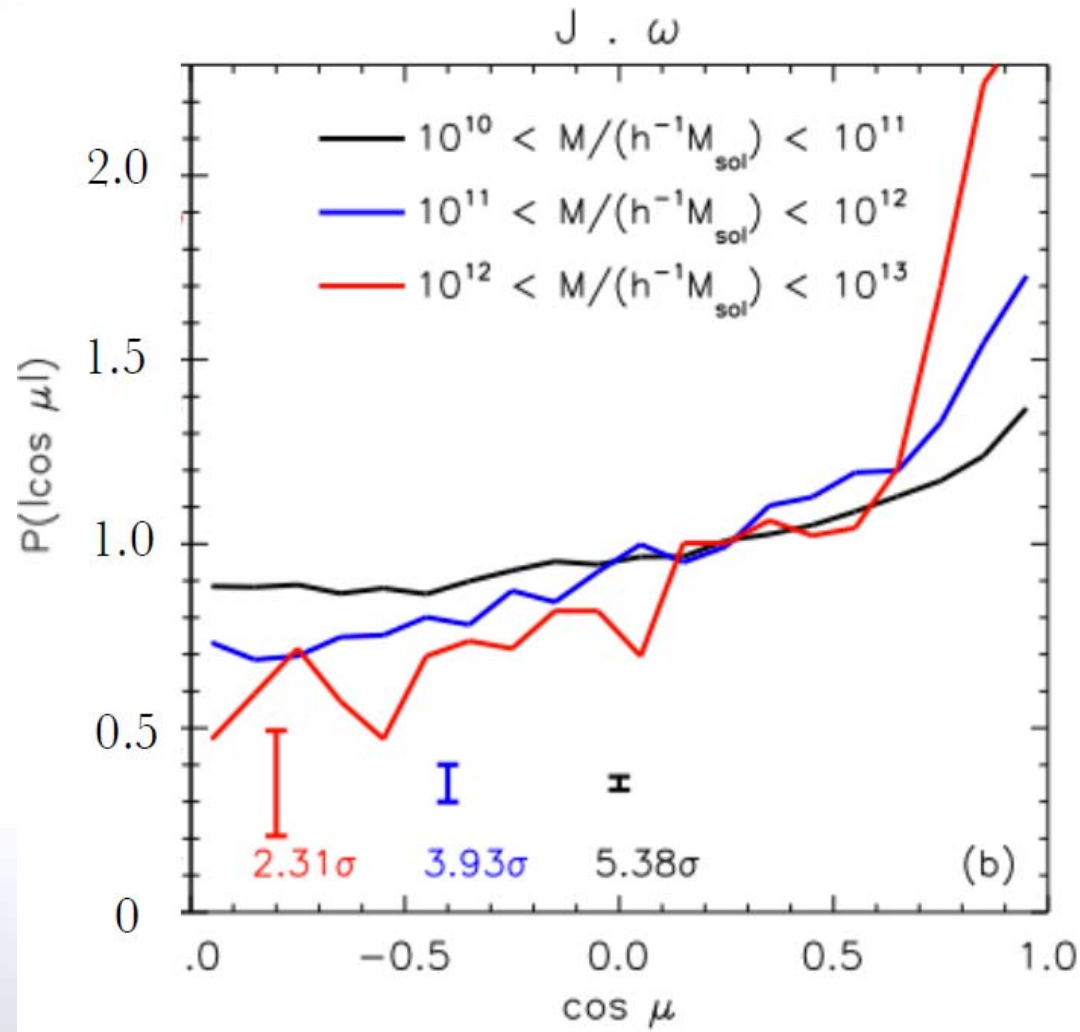

- Libeskind et al. (2013)

Vortical flow – *vorticity orientation*

- halo spin & cosmic web

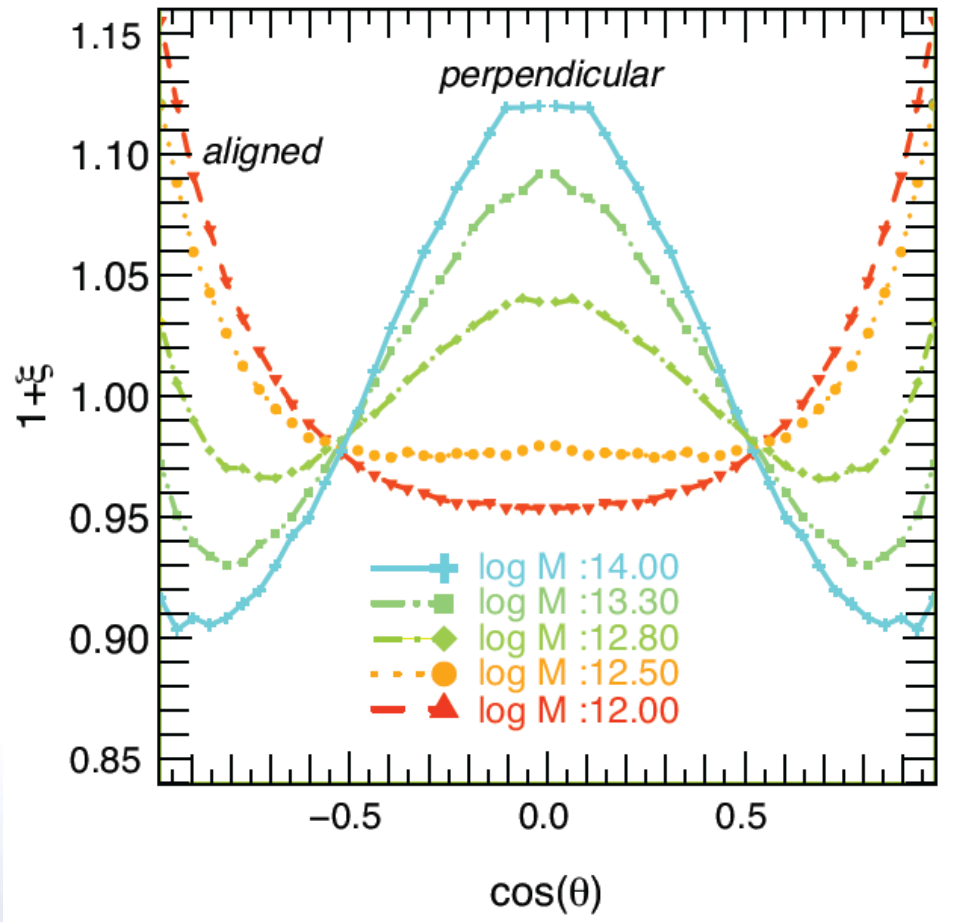

- Pichon et al.

Shell-crossing and Vorticity

- Multi-streaming
 - Vlasov-Poisson equation

$$\frac{\partial f}{\partial \tau} + \frac{\mathbf{p}}{am} \cdot \frac{\partial f}{\partial \mathbf{x}} - am \nabla \Phi \cdot \frac{\partial f}{\partial \mathbf{p}} = 0,$$

$$\rho = \int d^3 \mathbf{p} f(\mathbf{x}, \mathbf{p}, \tau), \quad u_i = \int d^3 \mathbf{p} f(\mathbf{x}, \mathbf{p}, \tau) \frac{p_i}{am},$$
$$\zeta_{ij} = \int d^3 \mathbf{p} f(\mathbf{x}, \mathbf{p}, \tau) \left(\frac{p_i}{am} - u_i \right) \left(\frac{p_j}{am} - u_j \right), \quad (60)$$

$$\frac{\partial \mathbf{u}}{\partial \tau} + \mathcal{H}(\tau) \mathbf{u}(\mathbf{x}, \tau) + \mathbf{u}(\mathbf{x}, \tau) \cdot \nabla \mathbf{u}(\mathbf{x}, \tau) =$$
$$-\nabla \Phi(\mathbf{x}, \tau) - \frac{1}{\rho} \nabla_j (\rho \zeta_{ij}),$$

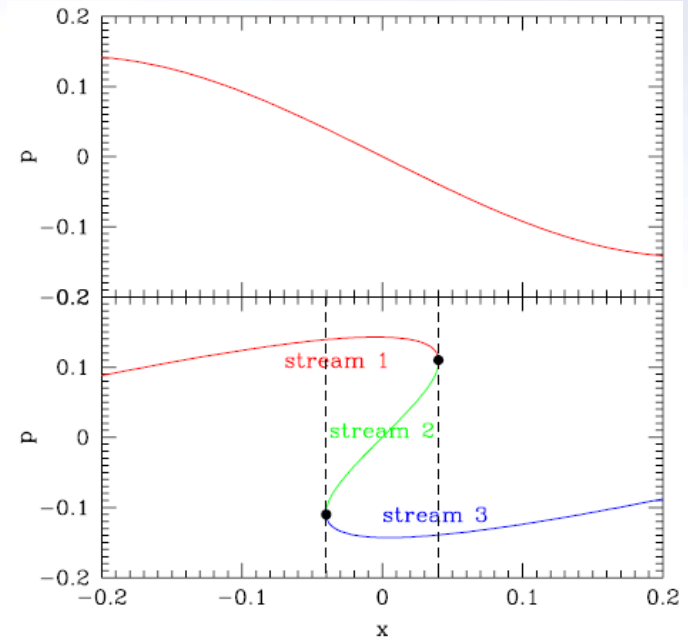

Shell-crossing and Vorticity

$$\frac{dA_{ij}}{d\tau} + \mathcal{H}(\tau)A_{ij} + A_{ik}A_{kj} = \varpi_{ij} + \zeta_{ij},$$

$$\zeta_{ij} = -\nabla_j \left[\frac{1}{\rho} \nabla_k (\rho \zeta_{ik}) \right].$$

- Invariants with velocity dispersion

$$\frac{d}{d\tau} s_1 + \mathcal{H}(\tau)s_1 - s_1^2 + 2s_2 = -\varpi - \zeta$$

$$\frac{d}{d\tau} s_2 + 2\mathcal{H}(\tau)s_2 - s_1s_2 + 3s_3 = -s_1(\varpi + \zeta) - \varpi_A - \zeta_A$$

$$\begin{aligned} \frac{d}{d\tau} s_3 + 3\mathcal{H}(\tau)s_3 - s_1s_3 = & -s_2(\varpi + \zeta) - s_1(\varpi_A \\ & + \zeta_A) - \varpi_{A^2} - \zeta_{A^2} \quad (64) \end{aligned}$$

Where

$$\begin{aligned} \frac{\partial \zeta_{ij}}{\partial \tau} + 2\mathcal{H}(\tau)\zeta_{ij} + (\mathbf{u} \cdot \nabla)\zeta_{ij} + \zeta_{jk} \nabla_k u_i + \zeta_{ik} \nabla_k u_j \\ = -\frac{1}{\rho} \nabla_k (\rho \pi_{ijk}), \end{aligned}$$



Shell-crossing and Vorticity

$$\frac{dA_{ij}}{d\tau} + \mathcal{H}(\tau)A_{ij} + A_{ik}A_{kj} = \varpi_{ij} + \zeta_{ij},$$

$$\zeta_{ij} = -\nabla_j \left[\frac{1}{\rho} \nabla_k (\rho \zeta_{ik}) \right].$$

- Invariants with velocity dispersion

$$\frac{d}{d\tau} s_1 + 2\mathcal{H}(\tau)s_1 - s_1^2 = -s_1(\varpi + \zeta) - \varpi_A - \zeta_A$$

Highly Non-linear

$$\frac{d}{d\tau} s_2 + 2\mathcal{H}(\tau)s_2 - s_1s_2 + 3s_3 = -s_1(\varpi + \zeta) - \varpi_A - \zeta_A$$

$$\begin{aligned} \frac{d}{d\tau} s_3 + 3\mathcal{H}(\tau)s_3 - s_1s_3 = & -s_2(\varpi + \zeta) - s_1(\varpi_A \\ & + \zeta_A) - \varpi_{A^2} - \zeta_{A^2} \quad (64) \end{aligned}$$

Where

$$\begin{aligned} \frac{\partial \zeta_{ij}}{\partial \tau} + 2\mathcal{H}(\tau)\zeta_{ij} + (\mathbf{u} \cdot \nabla)\zeta_{ij} + \zeta_{jk}\nabla_k u_i + \zeta_{ik}\nabla_k u_j \\ = -\frac{1}{\rho} \nabla_k (\rho \pi_{ijk}), \end{aligned}$$



Emergence of Vorticity

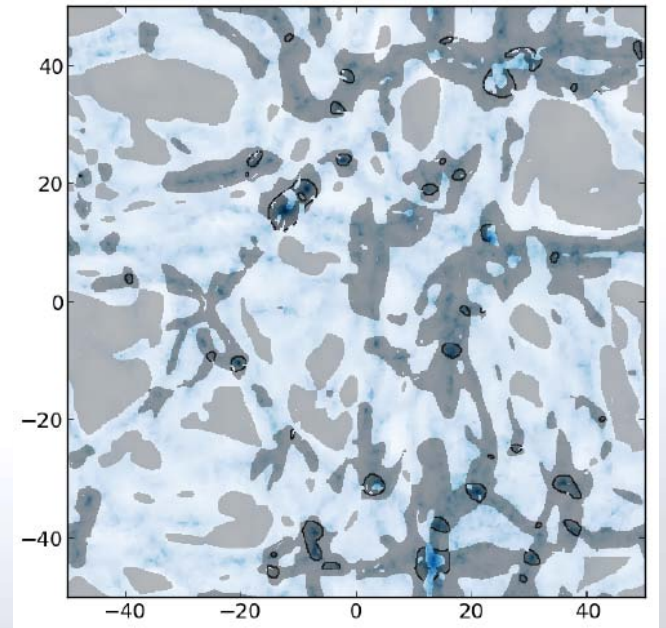
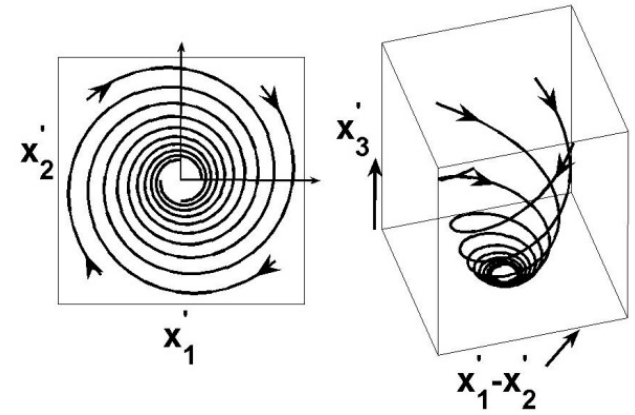
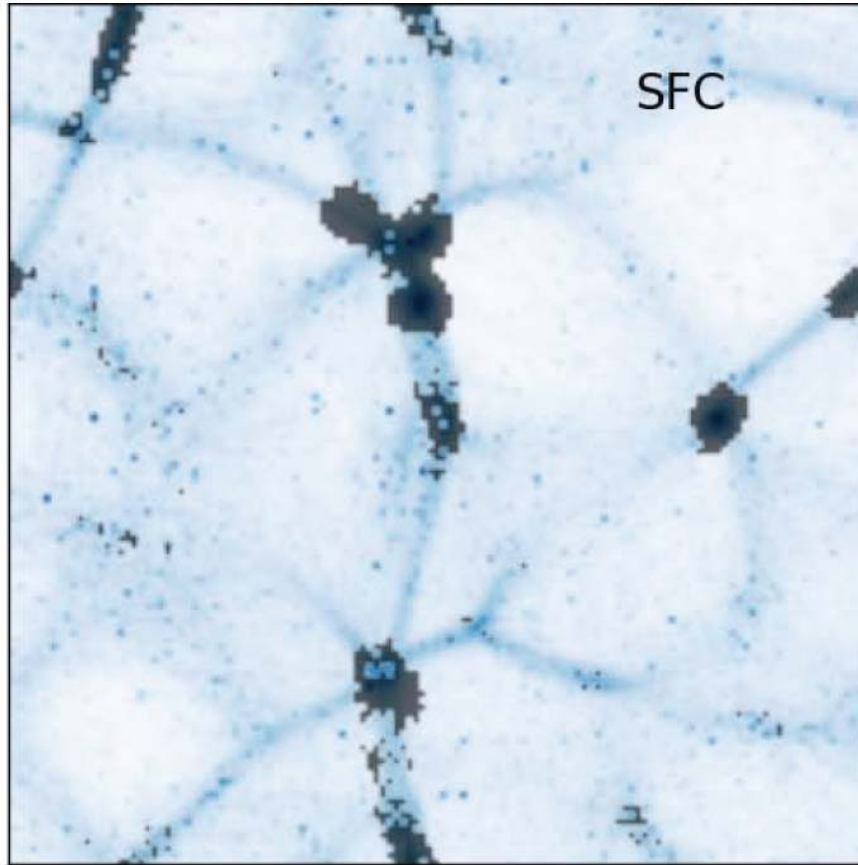

Potential – Vortical transition

$$s_1 > 0,$$

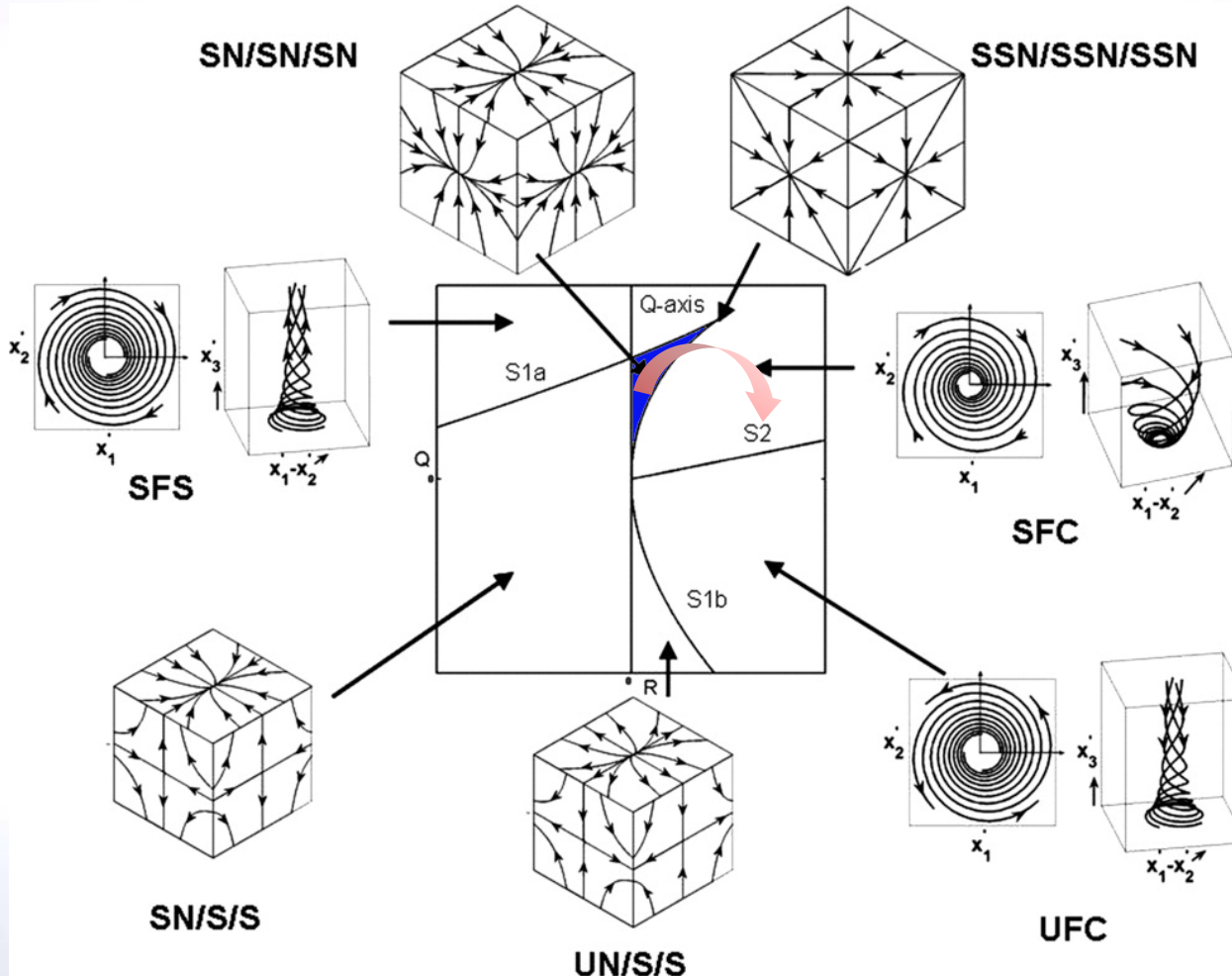

Potential – Vortical transition

$$s_1 > 0,$$

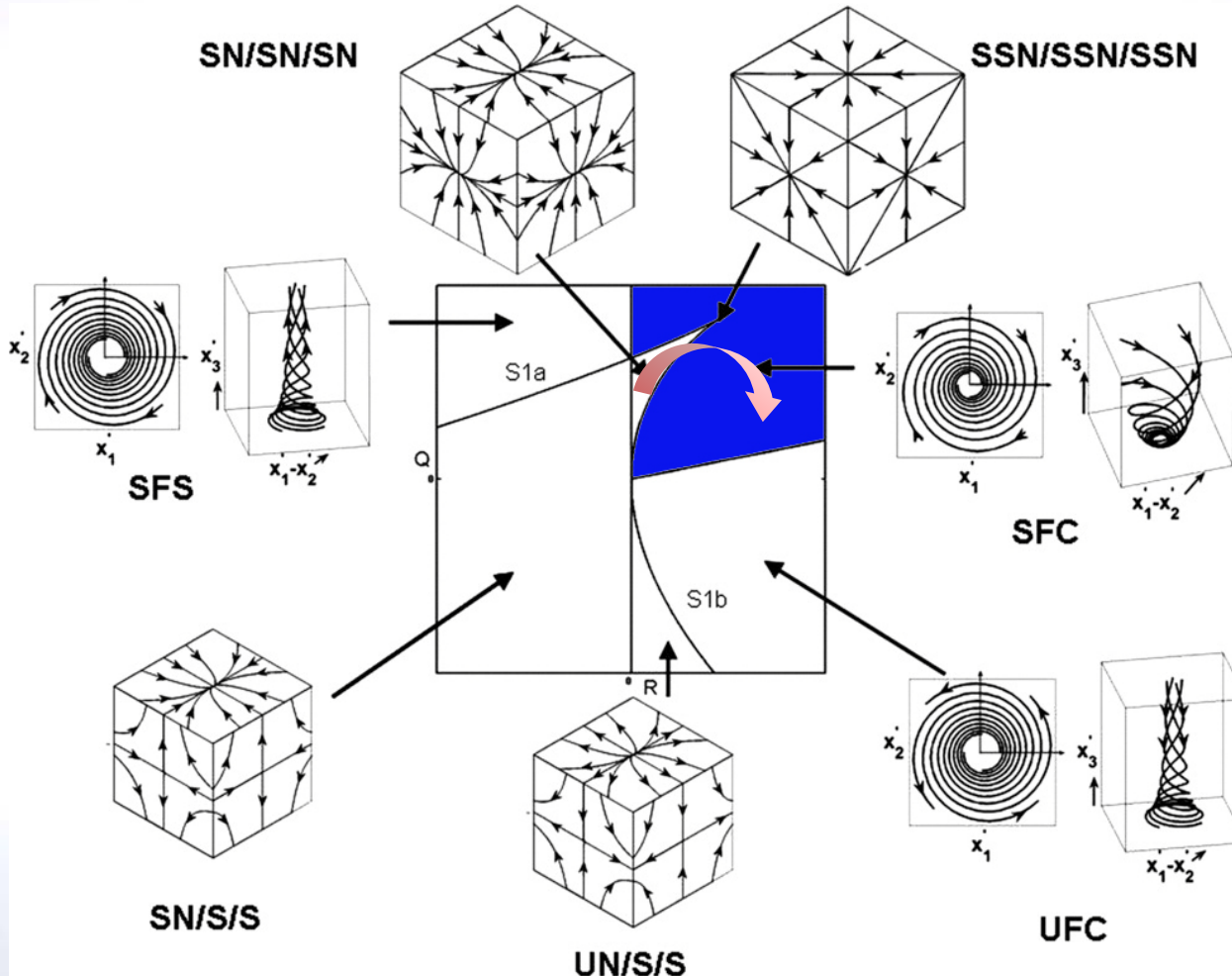

Potential – Vortical transition

$s_1 > 0,$

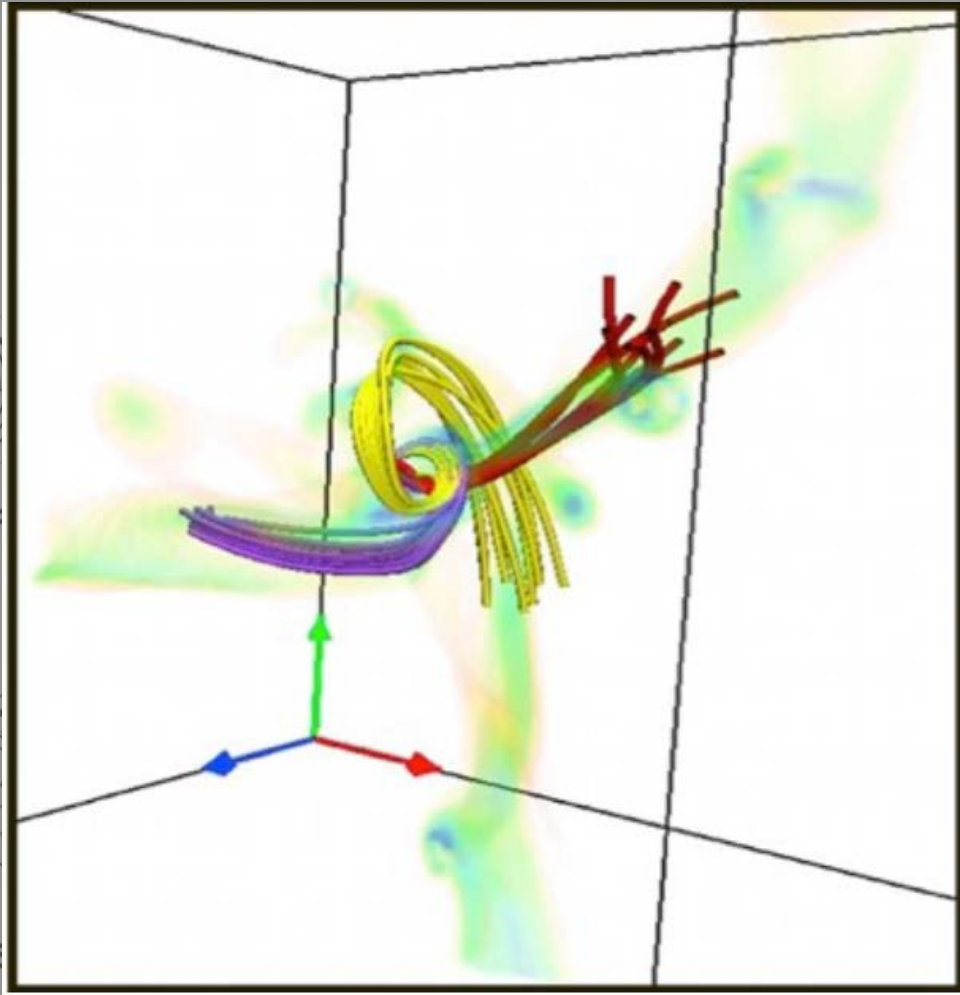

• Pichon, C. et al

Emergence of Vorticity

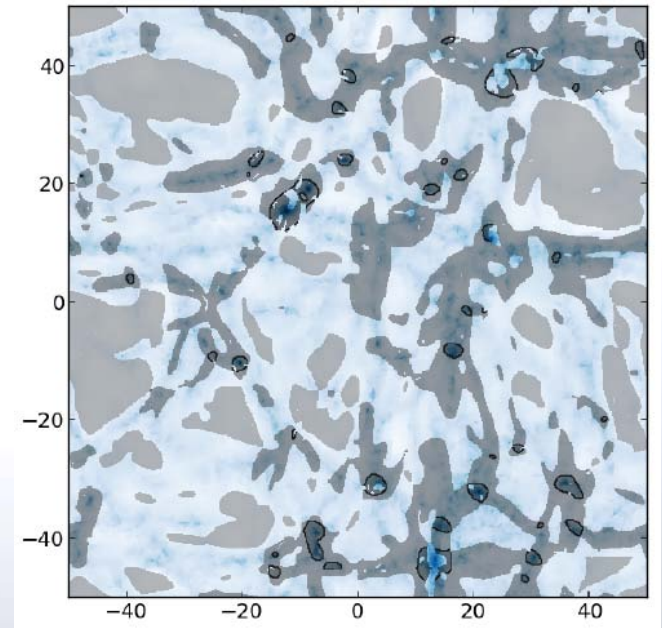
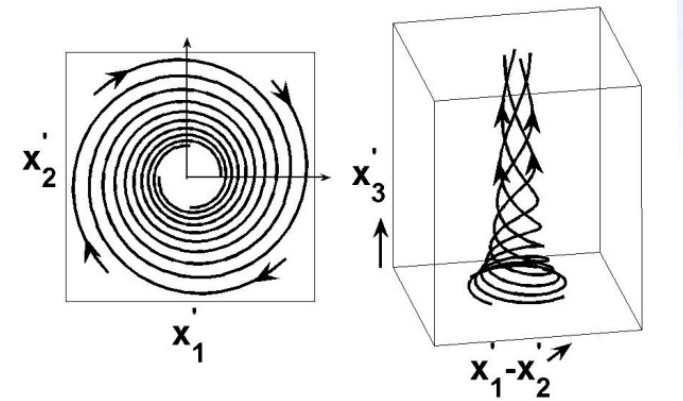
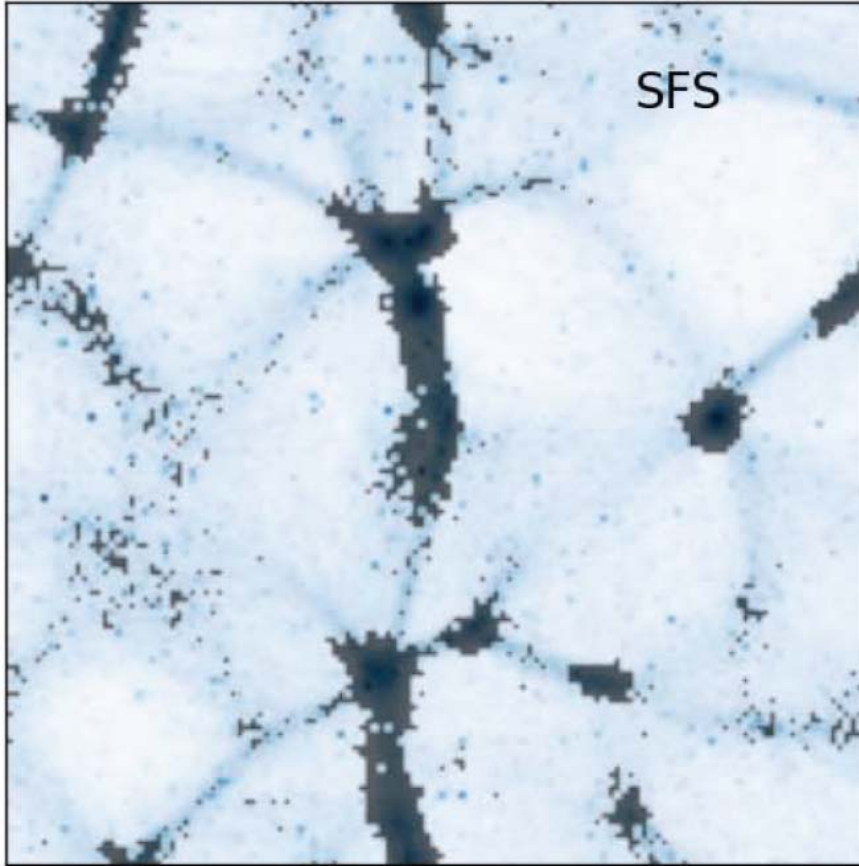

Potential – Vortical transition

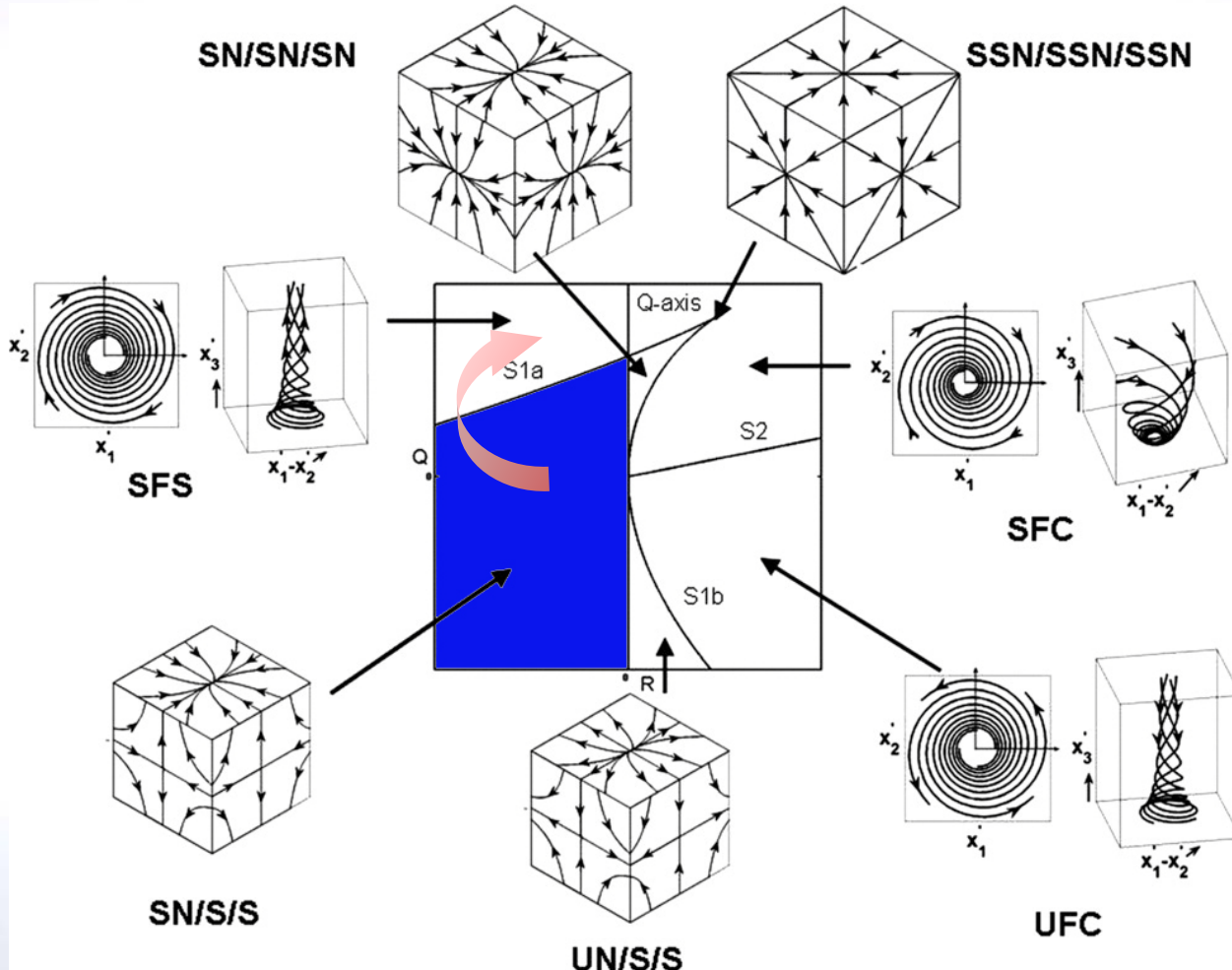

Potential – Vortical transition

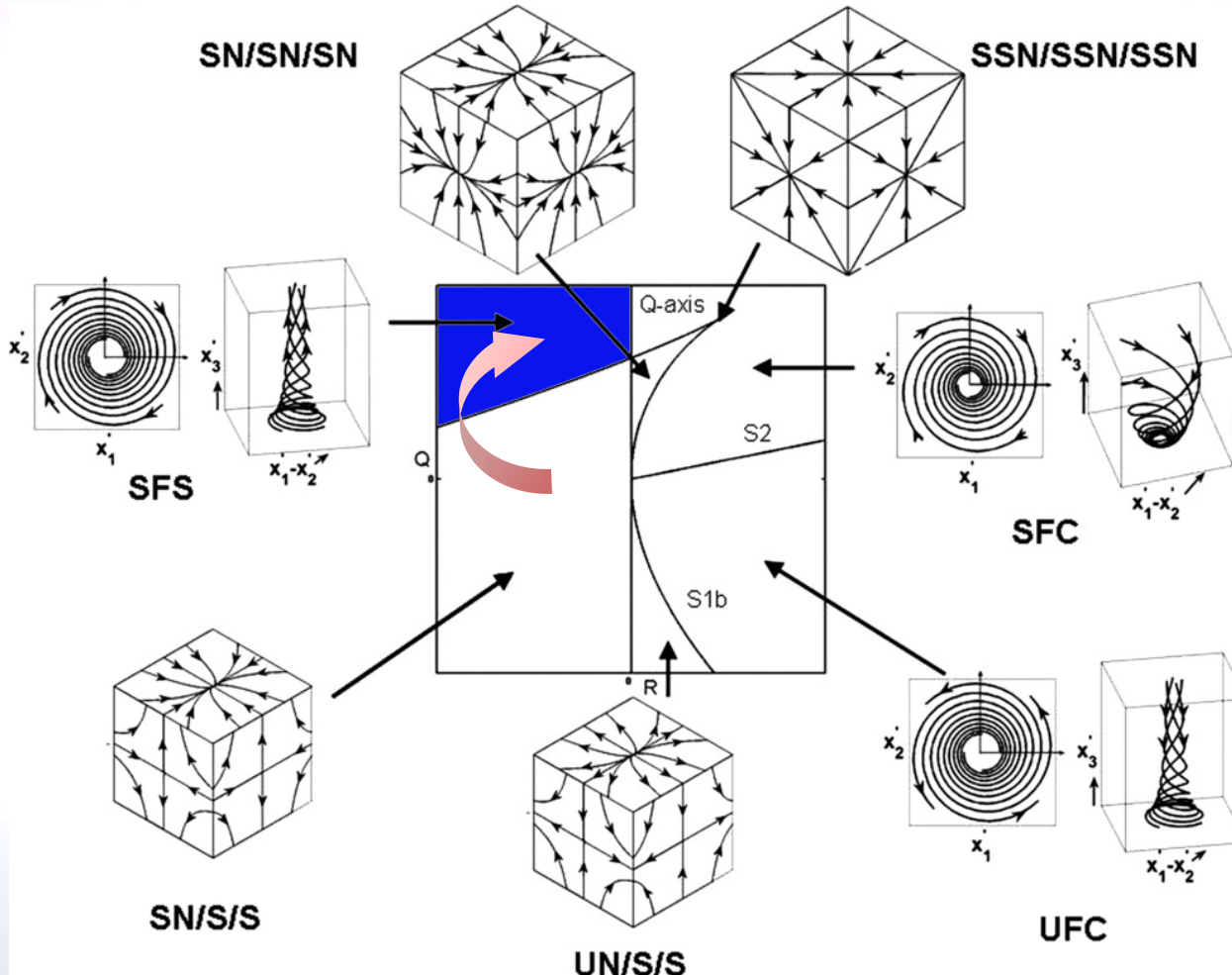

Summary

- **Coherent evolution of halo/galaxy spin, vorticity and large-scale structure**
- **Vorticity is generated in a particular way that related to cosmic web structure**
- **Environmental dependence is inherited from potential to vortical flow, and eventually to the halo/galaxy spin**



Kinematics of Cosmic Web

Thank you !



Galaxy formation in Cosmic Web

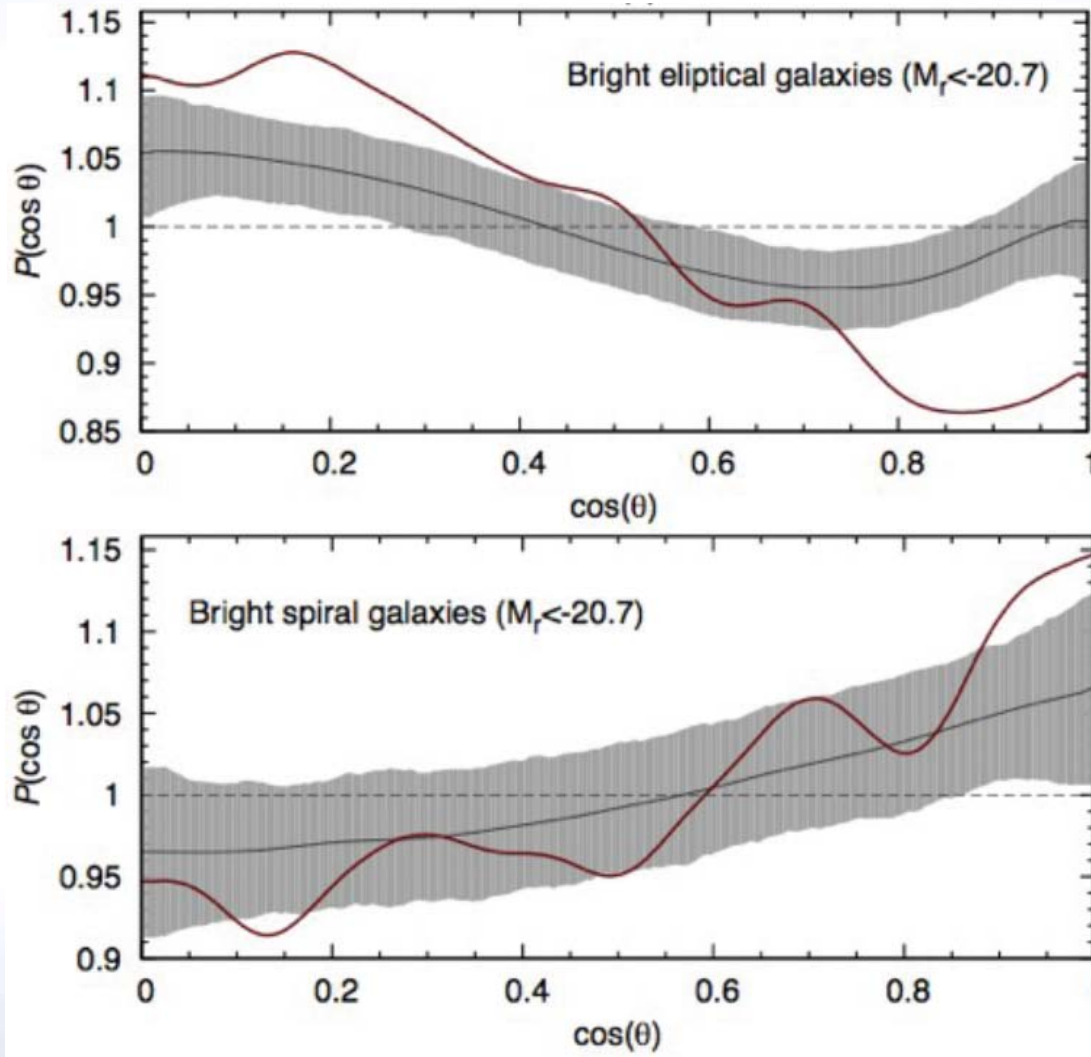

- Tempel et al (2013)

